

Dimensions

Top performance in compact enclosure

TMU-W 004 Ultra compact feather-weight

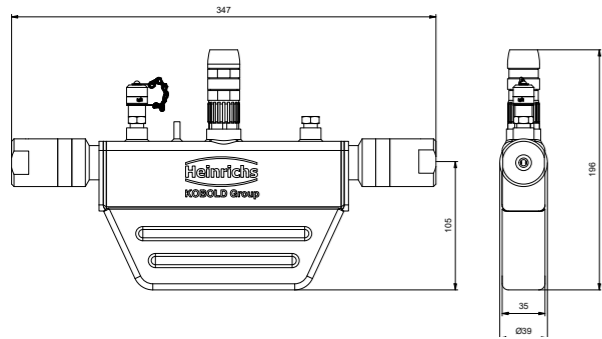

UMC4 - reliable proven transmitter

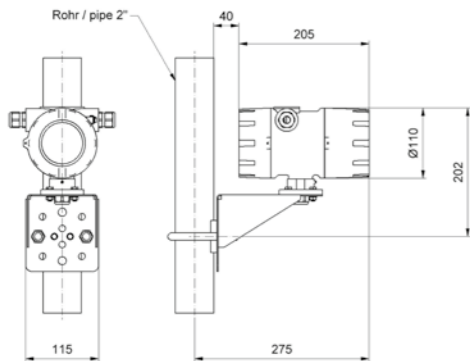

Weight: 2.8 kg sensor
4.5 kg transmitter

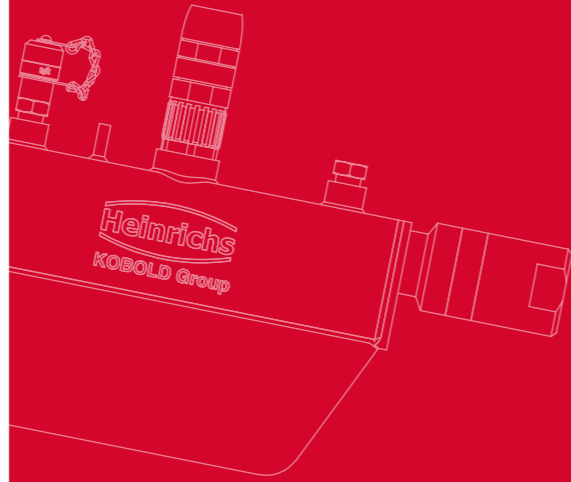

Heinrichs
KOBOLD Group

OVER 100 YEARS OF EXPERIENCE IN PROCESS-INSTRUMENTATION
We measure flow, mass, density, level and pressure

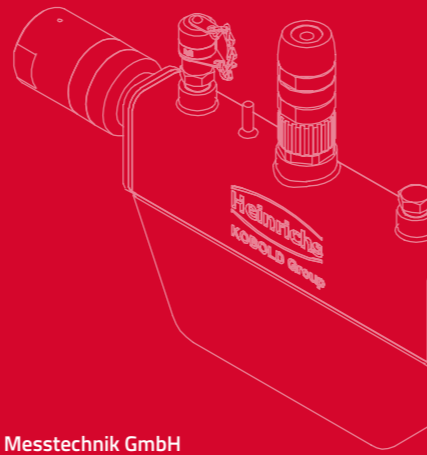

Heinrichs Messtechnik GmbH
Robert-Perthel-Straße 9 | 50739 Köln
Tel. 49 (0)221-49708 0
Fax. 49 (0)221-49708 178
info@heinrichs.eu | www.heinrichs.eu

Heinrichs
KOBOLD Group

OVER 100 YEARS OF EXPERIENCE IN PROCESS-INSTRUMENTATION
We measure flow, mass, density, level and pressure



Hydrogen - measurement with precision High-pressure coriolis mass-flow meter

- > H₂-application optimized
- > 1000+ bar working pressure
- > OIML R139:2018 approval
- > SAE J2601 Fueling
- > Compact and innovative design

HIGH PRESSURE - CORIOLIS FOR H₂ TMU - W

Hydrogen as an ecological alternative
Developed with commitment

The human influence on the global climate has become increasingly obvious, for which the high energy needs of modern societies play a significant role. To counteract this development, environmentally friendly technologies must become more suitable for everyday use. Hydrogen, with its high efficiency but minimal impact on the environment, is the ideal ecological alternative to achieve this goal and is destined to play a special role in replacing fossil fuels energy fossil fuel energy sources.

Heinrichs has played an active role in the high-pressure hydrogen sector providing H₂ vehicle dispenser measuring solutions for more than 10 years. To achieve the necessary high energy density with elemental Hydrogen, the lightest of all elements, an appropriate compression is required. Pressures greater than 1000 bar as well the high permeability of hydrogen therefore pose the greatest technical challenges for the technology.

Driven by our gained experience, the requirements of modern applications and the latest technological advances, Heinrichs has developed the new TMU-W product range, with a Coriolis architecture specially designed for high-pressure Hydrogen applications.



The TMU-W Coriolis mass-flow meter Heinrichs not only conforms to, but surpasses by far all requirements of the "Organization Internationale de Métrologie Légale" in the OIML R139-2018 in terms of measuring accuracy at high pressure.

HIGH PRESSURE - CORIOLIS FOR H₂ TMU - W

"High End" Simulation technology
Futuristic design for future technology

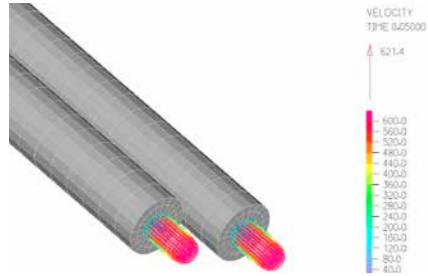

For the development of the **TMU-W** the latest techniques in the simulation of structure and flow conditions were applied.

- CSM** (Computational Structural Mechanics)
- FEM** (Finite Element Method)
- CFD** (Computational Fluid Dynamics)
- CEM** (Computational Electromagnetics)
- FSI** (Fluid Structure Interaction)
- TFSI** (Thermal Fluid Structural Interaction)

These techniques allow a precise virtual assessment of complex, coupled behaviours meaning the specific characteristics of H₂ high-pressure measurement can be addressed directly. The result was the rapid development of an optimised Coriolis sensor.

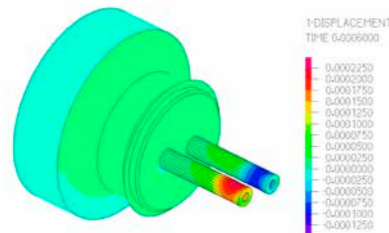

The future lies in Hydrogen mobility
The expansion of the H₂ infrastructure strides ahead

Mobility is the engine of our lives and should become environmentally friendly today rather than tomorrow.

Pure electric mobility is already environmentally friendly and present in everyday life, but it also has clear limitations. Hence, there is no alternative to hydrogen technology on the highway into the future.



Highly compressed hydrogen as an Energy source for vehicles will soon be indispensable. Familiar comforts such as high vehicle ranges and refuelling within 3 minutes are only possible with hydrogen.

The expansion of the hydrogen dispenser station network has been adopted by many governments and is rapidly forging ahead.



A whole industry is therefore working full-steam to develop new solutions and technologies around this energy source and to provide applications suitable for everyday use - and in its midst **Heinrichs** is the partner of choice.

Heinrichs Coriolis mass-flow meters
Always upfront, especially with hydrogen

Limitless application possibilities for Heinrichs hydrogen flowmeters.

The **TMU-W** was specially designed for use in hydrogen dispenser stations. As an all-rounder, it can just as well be utilised in high pressure applications of liquids offering a measurement accuracy of 0.1%.



Optimized for use in slim hydrogen dispensers of the latest state-of-the-art generation, our **TMU-W**, with its small dimensions and low weight, is a particularly compact mass-flow meter allowing so a direction-independent installation in the dispenser, as well as direct installation close to the fuelling nozzle, so with having the additional advantage of minimizing losses when refuelling.

Technical details
Highlights

Sensor TMU-W004		
Measuring range	max. 4 kg / min H ₂	
Process pressure	1000 bar (TMU-W004)	
Accuracy	± 0.5 % of reading ± zero point stability	
Material	316 TI / 1.4571 (Wetted parts)	
Connections	Autoclave 6MF 9/16-18, ½ NPT F, Hofer 7/8", 12 MF ¾-16	
Temperature	- 40 ... 60 °C (process) - 40 ... 60 °C (environment)	

Measuring transmitter UMC4		
Supply voltage	19...36 V _{DC}	
Signal	two-fold 90° phase-shifted intrinsically safe pulse outputs. 4...20 mA HART (passive)	
Temperature	- 40...60 °C (environment)	
Protection class	IP 68 (EN 60529)	
Explosion protection	II (1)2G Ex d [ia Ga] IICT3-T4 Gb	
Certificates	OIML R139 Evaluation ATEX type approval IECEX type approval KCS approved (S. KOREA) NEPSI approved (China)	

