



Coriolis Mass Flow Meter

UMC3 with
TM, TME,
TMU, TMR
TM-SH

Supplementary Operating Manual for
explosion-proof flow meters



This operating manual contains important information for the operation in potentially explosive atmospheres
Please read the instructions carefully and store them in a safe place for future reference

CONTENTS

INTRODUCTION.....	4
I. Shipping and storage; product inspection	4
II. Warranty.....	4
III. Validity of this operating manual	4
IV. Repairs and hazardous materials	4
1. STEPS PRIOR TO OPERATION	5
1.1 Installation, mounting, commissioning and maintenance.....	5
1.2 Hazard warnings	6
1.3 Proper use of the device	6
2. IDENTIFICATION	7
3. GENERAL INFORMATION ABOUT EXPLOSION PROTECTION	8
4. CORIOLIS MASS FLOW METER	9
4.1 Description of the TM, TME, TMU and TMR sensors	9
4.1.1 Device identification	9
4.1.2 Mounting	10
4.1.2.1 Thermally insulated sensor	10
4.1.2.2 Heated sensor.....	10
4.1.2.3 Connection sensor – transmitter.....	10
4.1.3 EC Type-Examination Certificate for the sensors type TM, TME, TMU, TMR and TM-SH.....	11
4.1.3.1 Sensor Parameters	12
4.1.3.2 TMx Sensor temperature ranges	13
4.2 Description of the UMC3 transmitter	14
4.2.1 Device identification	14
4.2.2 Ignition category of the transmitter	15
4.2.2.1 Marking when equipped with Ex e or Ex d terminal compartments	15
4.2.3 Terminal compartment	15
4.2.3.1 Ex e i type of protection terminal compartment.....	15
4.2.3.2 Ex d and Ex d / Ex i type of protection terminal compartment	15
4.2.3.3 Equipotential bonding	16
4.2.4 Connecting cables.....	16
4.2.4.1 Sensor circuits.....	16
4.2.5 Parameters for the UMC3 transmitter	17
4.2.5.1 Power circuit (terminals L, N and PE).....	17
4.2.5.2 Non-intrinsically safe circuits for Type UMC3-****2	17
4.2.5.3 Type of protection Ex ia II sensor circuits	17
4.2.5.4 Signal output circuits	18
4.2.5.5 Bus Communication circuits	20

4.2.6	UMC3 Ambient Temperature Ranges	21
4.2.6.1	Standard temperature ranges.....	21
4.2.6.2	Extended ambient temperature range	22
4.3	The Control Unit BE2	23
4.3.1	Connection of the converter during commissioning	23
4.3.2	Procedure for Configuration.....	24
5.	INSTALLATION AND COMMISSIONING.....	25
5.1	Special conditions for safe use for the UMC3	25
5.2	General conditions for safe operation.....	25
5.3	Requirements for installation in all environments.....	26
5.4	Ex relevant screw and bolt torques	26
6.	MAINTENANCE AND REPAIR WORK.....	27
6.1	Definition of terms according to IEC 60079-17:	27
6.2	Recommended inspection intervals	27
7.	WARNING NOTICES.....	28
8.	MODEL CODES	29
8.1	The Transmitter UMC3	29
8.2	The TM Sensor	30
8.3	The TMU Sensor	31
8.4	The TME Sensor.....	32
8.5	The TMR Sensor	33
8.6	The TM-SH Sensor.....	34
9.	EC DECLARATION OF CONFORMITY	35

Introduction

I. Shipping and storage; product inspection

The device is to be safeguarded against moisture, dirt, impact and damage.

Product inspection

Upon receipt of the product, the consignment should be checked for completeness. The data of the device have to be compared with the packing slip and the order documents

Notify us of any shipping damage immediately upon receipt of the product. Any damage claim received at a later time will not be honored.

II. Warranty

Your flow meter was manufactured in accordance with the highest quality standards and was thoroughly tested prior to shipment. However, in the event any problem arises with your device, we will be happy to resolve the problem for you as quickly as possible under the terms of the warranty which can be found in the terms and conditions of delivery. Your warranty will only be honored if the device was installed and operated in accordance with the instructions for your device. Any mounting, commissioning and/or maintenance work is to be carried out by qualified and authorized technicians only.

III. Validity of this operating manual



Note! The present instructions apply to explosion-proof Coriolis flow meters TM/TME/TMU/TMR and TM-SH series which are operated in conjunction with the UMC3 transmitter **as of year of construction October 2018 or later.**

These instructions are supplementary operating manual for non-explosion proof Coriolis flow meters. If you do not have a copy of the latter instructions, please request one from Heinrichs Messtechnik GmbH or download the instructions from our website.

The instructions herein pertain primarily to explosion proof Coriolis flow meters. The technical data in the mounting and operating instructions for non-explosion proof Coriolis flow meters still apply insofar as the present instructions do not replace them or exclude their application.

IV. Repairs and hazardous materials

It is important that you do the following before shipping your flow meter to Heinrichs Messtechnik GmbH for repair:

- Enclose a description of the problem with your device. Describe in as much detail as possible the application and the physical and chemical properties of the fluid.
- Remove any residues from the device and be sure to clean the seal grooves and recesses thoroughly. This is particularly important if the fluid is corrosive, toxic, carcinogenic, radioactive or otherwise hazardous.

The operator is liable for any substance removal or personal damage costs arising from inadequate cleaning of a device that is sent for repair.

1. Steps prior to operation

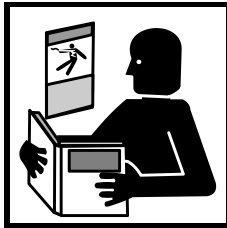

Prior to installation and operation, it is essential that the operator familiarizes himself with all of the instructions and information contained in the manual for non-explosion proof Coriolis flow meters as well as the present instructions. If any part of either manual is missing, contact Heinrichs Messtechnik GmbH to request a new manual. These manuals can also be downloaded from our website.

The UMC3 transmitter described herein is only to be used to measure mass and volume flow, as well as liquid and gas density and temperature, in conjunction with a Heinrichs Messtechnik GmbH TM, TME, TMU, TMR or TM-SH sensor.

1.1 Installation, mounting, commissioning and maintenance

Installation, mounting, commissioning and maintenance are to be performed by a technician trained to work with explosion-proof devices, or by a Heinrichs Messtechnik service technician.



Warning

Any maintenance or repair that safety relevant in terms of explosion-protection is to be carried out by the manufacturer, an authorized Heinrichs

Heinrichs Messtechnik GmbH accepts no liability for any loss or damage of any kind arising from improper operation of any product, improper handling or use of any replacement part, or from external electrical or mechanical effects, overvoltage or lightning. Any such improper operation, use or handling shall automatically invalidate the warranty for the product concerned.

In the event of a problem please contact the service center of Heinrichs Messtechnik:

Phone: +49 221 49708-0

Fax: +49 221 49708-178

Contact our customer service department if your device needs repair or if you need assistance in diagnosing a problem with your device.

1.2 Hazard warnings

The purpose of the hazard warnings listed below is to ensure that device operators and maintenance personnel are not injured and that the flow meter and any devices connected to it are not damaged.

The safety advisories and hazard warnings in the present document that aim to avoid placing operators and maintenance personnel at risk and to avoid material damage are prioritized using the terms listed below, which are defined as follows in regard to the instructions herein and the advisories pertaining to the device itself.

Warning



means that failure to take the prescribed precautions **could result** in injury, substantial material damage or even death. Always comply to these warnings and proceed with caution.

Caution



means that failure to take the prescribed precaution **could result** in material damage or destruction of the device. We advise always to abide to these instructions!

Note



means that the accompanying text contains important information about the product, handling the product or about a section of the documentation that is of particular importance.

1.3 Proper use of the device



Warning

The operator is responsible for ensuring that the material used in the sensor and transmitter housing is suitable and that such material meets the requirements for the fluid being used and the ambient site conditions. The manufacturer accepts no responsibility in regard to such material and housing.



Warning

In order for the device to perform correctly and safely, it must be shipped, stored, set up, mounted operated and maintained properly.

2. Identification

Manufacturer: Heinrichs Messtechnik GmbH
Robert-Perthel-Strasse 9
D-50739 Cologne
Germany



Phone: +49 221 49708-0

Fax: +49 221 49708-178



Internet: www.heinrichs.eu

Email: info@heinrichs.eu

Product type: Mass flow-rate meter for liquid and gaseous products

Product name: Sensor type: TM / TMU / TME / TMR / TM-SH
Transmitter type: UMC3

File name: umc3-tm_ex-ba_21.01_en.doc

Version: 21.01, dated January 31, 2021

3. General information about explosion protection

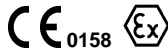
Acc. Directive 94/9/EC (ATEX)	Example designation				II	2G	Ex	ia	IIC	T6	Gb
	Equipment groups										
	I	Equipment group I applies to equipment intended for use in underground parts of mines as well as those parts of surface installations of such mines endangered by firedamp and/or combustible dust.									
	II	Equipment group II applies to equipment intended for use in other places liable to be endangered by explosive atmospheres. This group is subdivided into three categories.									
	Equipment category										
	Gas	Dust	Definition								
	1G (0)	1 D (20)	Equipment in this category is intended for use in areas in which explosive atmospheres caused by mixtures of air and gases, vapours or mists or by air/dust mixtures are present continuously, for long periods or frequently.								
	2 G (1)	2 D (21)	Equipment in this category is intended for use in areas in which explosive atmospheres caused by gases, vapours, mists or air/dust mixtures are likely to occur.								
	3G (2)	3D (22)	Equipment in this category is intended for use in areas in which explosive atmospheres caused by gases, vapours, mists, or air/dust mixtures are unlikely to occur or, if they do occur, are likely to do so only infrequently and for a short period only.								
	(The numbers in round brackets correspond to the IEC Zones.)										
Acc. EN 60079-0 ff / IEC 60079-0 ff	Ex = Explosion-proof electrical equipment										
	Types of protection										
		General requirements	IEC 60079-0								
	„d“	Flameproof enclosure	IEC 60079-1								
	„e“	Increased safety	IEC 60079-7								
	„i“	Intrinsic safety (ia, ib)	IEC 60079-11								
	„t“	Equipment dust ignition protection by enclosure "t" (ta, tb or tc)	EN 60079-31								
	Explosion groups										
	Gases and vapours										
	IIA	Acetone, benzene, fuel oil, ethanoic acid									
IIB	City gas, ethylene, isoprene										
IIC	Acetylene, hydrogen, carbon bisulphide										
Dust Atmospheres											
IIIA	Fibers and flyings										
IIIB	Non-conductive dusts										
IIIC	Metal dusts										
Temperature classes											
	Maximum surface temperature	Temperature class									
450 °C	842 °F	T1									
300 °C	572 °F	T2									
200 °C	392 °F	T3									
135 °C	275 °F	T4									
100 °C	212 °F	T5									
85 °C	185 °F	T6									
Equipment protection level, EPL											
Gases: Ga, Gb oder Gc		Dust: Da, Db or Dc									

Explosion protection designations [square brackets] refer to "Related electrical equipment or circuits."

4. Coriolis mass flow meter

4.1 Description of the TM, TME, TMU and TMR sensors

The TMU sensor is an "Intrinsic safety" type of protection device that is outfitted with the following four independent potential-free circuits: These circuits are safely separated in the sensor

- Excitation circuit
- Sensor circuit 1
- Sensor circuit 2
- Temperature sensor circuit (PT1000)

If the transmitter is mounted externally, it should be connected to the sensor using a Heinrichs Messtechnik cable that is specially designed for this purpose.







Although the appearance of the standard and explosion-proof transmitters is identical and their rating plates contain the same information, **under no circumstances should a standard (non-explosion proof) transmitter be connected to an explosion-proof sensor!**

4.1.1 Device identification

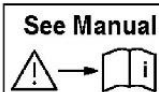
The rating plates on Heinrichs Messtechnik flow meters that are suitable for use in potentially explosive atmospheres are labeled accordingly. Since the sensor and transmitter have different ratings, each device has its own rating plate.

TM/TME/TMU/TMR/TM-SH rating plate

Example: TM for process temperatures ranging from - 40 °C to 100 °C.

 KOBOLD Group D-50739 Köln Robert-Perthel-Str. 9 Germany	 See Manual www.heinrichs.eu	Type: TM-T23-305I0350-R0L3-L-B-0-00 Ser. No.: 123456 MF-Date: 2018/10 TAG No.: TM008T*26958034 Tamb: -20°C to 60°C
	 CE 0158	CONNECTION: DN15 PN40 Form B 2 WETTED PARTS: Tantalum PROCESS TEMP.: -40°C to 100°C PS: 40 bar PT: 60 bar PED / Art.3 Para.4 PN BODY: 0 bar Qmin = 40 kg/h Qmax = 350 kg/h Sensor Constant C: 84,322 Cable fittings : M20 x 1,5mm
 DMT 01 ATEX E 149X II 1/2 G Ex ia IIC T2...T6 Ga/Gb  IECEx BVS 11.0084X Ex ia IIC T2...T6 Ga/Gb  NEPSI: GYJ17.1166X Ex ia IIC T2 .. T6 Ga/Gb  Class I Div 1 Group A,B,C,D Class I Zone 1: AEx ia TX Ga CSA18CA70171067X	Control Drawing: Consult Control TM-CSA-1100 Drawing for Warnings EXCITER CIRCUIT TYPE: EC1R	

4.1.2 Mounting

The mounting instructions for the standard sensor also apply to the explosion-proof sensor.

4.1.2.1 Thermally insulated sensor

The sensor may be outfitted with thermal insulation, also in explosive atmospheres. However, so not to impair the junction box or connectors thermal ratings, the insulation shall only cover maximum the half of the sensors adapter neck onto which the junction box or connector is mounted.

4.1.2.2 Heated sensor

To avoid crystallization in the flow tubes, the sensor can be externally heated. Any heating technique or device may be used. By use of electrical heating devices, these must be suitable for use in the potentially explosive environments.

It is the operator's responsibility to ensure that the heating temperature does not exceed the maximum allowable temperature for the fluid and/or the maximum allowable temperature range for the potentially explosive atmosphere in which the device is being operated.

The maximum allowable temperature range for the fluid is indicated on the flow meter rating plate.

It is also the operator's responsibility to ensure that no hazards are created by hot surfaces pursuant to EN 1127-1 (Explosive atmospheres - Explosion prevention and protection) paragraphs 5.2 and 6.4.2.

4.1.2.3 Connection sensor – transmitter

Compact meters (sensor and transmitter form a unit and are connected electrically)

The electrical connection is made by the manufacturer. Furthermore the proof of the intrinsic safety of the sensor circuits (according EN 60079-14) was carried out by the manufacturer and ensured. For these circuits no action is required by the operator.

Remote installation

A dedicated cable **SLI2Y (SP) CY 5 x 2 x 0.5 mm² [blue]** is to be used for the electrical connection between sensor and remote mount transmitter. This cable, which is available from Heinrichs Messtechnik, has five twisted pairs, each of which has a foil shield and filler cord. The filler cords are to be installed on the "shield" terminal in both the sensor and transmitter. The five twisted wire pairs are themselves shielded by tinned copper wire mesh. This external cable shield is connected to the housing via a dedicated EMC cable fitting, thus ensuring optimum noise immunity.

Sensor Cable

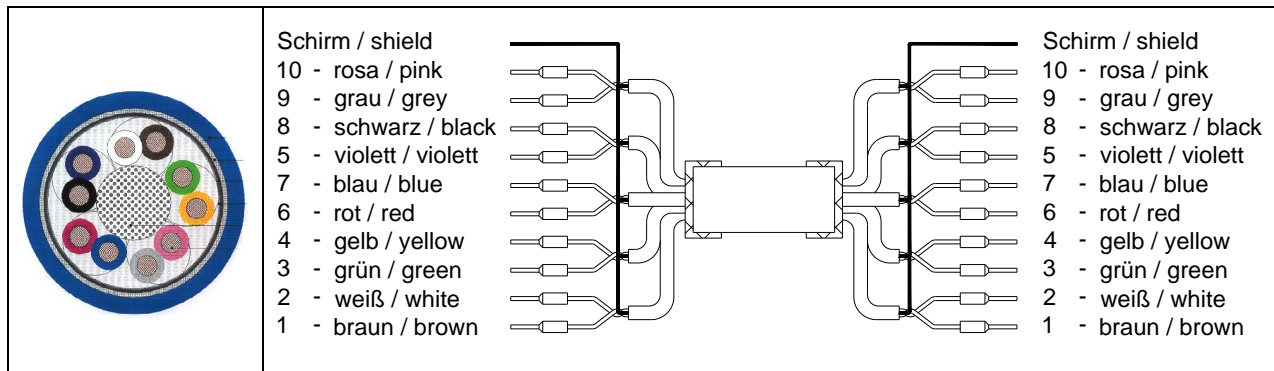

The operator is to comply in all cases with the applicable installation regulations such as EN 60079-14 "Electrical apparatus for explosive gas atmospheres- Part 14: Electrical installations in hazardous areas".

Applicable guidelines pertaining to the interconnection of intrinsically safe circuits must also be observed.

The following maximum values apply to the cable mentioned above:

$C_L = 100 \text{ pF/m}$ wire to wire

$L_L = 700 \text{ }\mu\text{H/km}$ wire to wire

$C_L = 170 \text{ pF/m}$ wire to shield

$L_L = 500 \text{ }\mu\text{H/km}$ wire to shield



Warning

If a connecting cable other than the Heinrichs Messtechnik cable is used, the intrinsic safety of the cable is to be validated using the cable's nominal values

4.1.3 EC Type-Examination Certificate for the sensors type TM, TME, TMU, TMR and TM-SH

The sensors are with the examination certificates



DMT 01 ATEX E 149 X
II 1/2G Ex ia IIC T6-T2 Ga/Gb



IECEx BVS 11.0084 X
Ex ia IIC T6-T2 Ga/Gb

approved for the use in potentially explosive atmospheres. (hazardous classified locations)

The sensor may be used in such a way that inside the measuring tubes explosive atmosphere may be present often or for a long time (Zone 0).



Warning

In order to comply with the requirements for explosive atmospheres, it is essential that the maximum electrical and thermal values set forth below are observed and adhered to.

4.1.3.1 Sensor Parameters

Exciter circuit (terminals 9 and 10)

For type EC1

Voltage	U _i	30 V
Current	I _i	90 mA
Power	P _i	0,4 W
Effective internal capacitance	C _i	negligible
Effective internal inductance	L _i	4,38 mH

For exciter circuit type EC2 (remote mount transmitter configuration)

For connecting an intrinsically safe circuit with the Ex ia IIC type of protection, with linear output characteristic and the following maximum values:

Voltage	U _o	30 V
Current	I _o	90 mA
Power	P _o	0.8 W

Sensor circuits (terminals 1 – 2 and 3 - 4)

Voltage	U _i	DC	30 V
Current	I _i		50 mA
Power	P _i		0,3 W
Effective internal capacitance	C _i		negligible
Effective internal inductance	L _i		14 mH
Output voltage	U _o		AC 0,3 V

Temperature sensor circuit (terminals 5 to 8)

Voltage	U _i	DC	30 V
Current	I _i		100 mA
Power	P _i		0,1 W
Effective internal capacitance	C _i		negligible
Effective internal inductance	L _i		negligible

4.1.3.2 TMx Sensor temperature ranges

Depending on type of connection, installation, process temperature and temperature class:

With Connector plug

Adapter	Process temperature (°C) (1)	Ambient temperature range (°C) (1)	Temperature class
without	40	-40 to +40	T6
without	60	-40 to +60	T5
without	60	-40 to +10	T4
60 mm	100	-40 to +100	T4
160 mm	120	-40 to +100	T4
160 mm	180	-40 to +100	T3
260 mm	220/260 ^{(2) (3)}	-40 to +100	T2

(1) The maximum ambient and process temperatures of the TM-SH are restricted to 60 °C and 100 °C respectively

(2) The maximum process temperature of 260 °C only short-term. Refer to section 3.1 for more details.

(3) The process temperatures 220/260 °C are only applicable for TM, TMU and TMR sensors

Remote mount configuration

Adapter	Process temperature (°C)	Ambient temperature range (°C)	Temperature class
without	40	-40 to +40	T6
without	60	-40 to +60	T5
without	100	-40 to +100	T4
100 mm	120	-40 to +100	T4
100 mm	180	-40 to +100	T3
200 mm	220/260 ^{(2) (3)}	-40 to +100	T2

(2) The maximum process temperature of 260 °C only short-term. Refer to section 3.1 for more details.

(3) The process temperatures 220/260 °C are only applicable for TM, TMU and TMR sensors

Integral mount configuration

Adapter	Process temperature (°C)	Ambient temperature range (°C)	Temperature class
without	40	-40 to +40	T6
without	60	-40 to +55	T5
without	100	-40 to +50	T4
100 mm	120	-40 to +50	T4
100 mm	150	-40 to +50	T3

Refer also to section 4.2.6





4.2 Description of the UMC3 transmitter

When used in conjunction with the sensor, the **UMC3** transmitter measures the mass flow of liquids and gases in pipelines. The transmitter can be mounted on the sensor or remote. The configuration can be carried out by using a built-in or standalone control unit. Thereby a high degree of adaptability to user requirements is ensured. Although the basic device settings, e.g. calibration data are factory-configured, the settings pertaining to measurement data output and evaluation are user definable.

The UMC3 drives the excitation of the oscillating system in the mass flow sensor and prepares the sensor signals (position sensor 1 and 2 and the temperature sensor Pt 1000). As a standard, 2 active analog outputs 4-20 mA and 2 passive binary outputs are available. (1 pulse **or** 1 frequency output, 1 status output). Through current output 1, an additional digital modulated data transmission via HART® is provided.

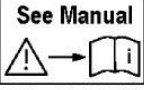
4.2.1 Device identification

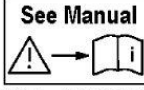
The UMC3 transmitter's identification plates are depicted in the following examples.

Terminal compartment: "Increased safety" and Signal outputs: intrinsically save	Terminal compartment: "Flameproof enclosure" and Signal outputs: not intrinsically save
<div style="border: 1px solid black; padding: 5px;">  <p>D-50739 Köln Robert-Perthel-Str. 9 www.heinrichs.eu</p> <p>CE 0158</p> <hr/> <p>Type: UMC3-B11A41 TAG No.: --- Ser. No.: 123456 MF-Date: 2016 / 11 Tamb: -20°C to +50°C  Supply: 90-265 V AC / 50/60Hz / 7,5 VA</p> <p> BVS 05 ATEX E 021 X II (1)2G Ex d e [ia Ga] IIB/IIC T6-T3 Gb</p> <hr/> <p>NEPSI Cert No. GYJ12.1040X Ex de [ia Ga] IIB/IIC T6/T5 Gb</p> <hr/> <p>Signal-outputs: Ex ia IIC / IIB I-OUT 4-20mA / HART, IMP-OUT, STATUS</p> <hr/> <p>Control unit BE2 II 2G Ex ia IIC T6 Gb Plug in only HEINRICHS transmitter</p> <hr/> <p>Sensor circuits Ex ia IIB / IIC</p> <hr/> <p>← Ex e Terminals</p> <p>WARNING - NON-INTRINSICALLY SAFE CIRCUIT PROTECTED BY INTERNAL IP30 COVER LID. WARNING - DO NOT OPEN EQUIPMENT AT THE PRESENCE OF EXPLOSIVE ATMOSPHERE. SEAL AT THE WALL OF ENCLOSURE.</p> <p style="text-align: right;">Ex d Compartment →</p> <hr/> <p>Cable fittings M20 x 1,5</p> </div>	<div style="border: 1px solid black; padding: 5px;">  <p>D-50739 Köln Robert-Perthel-Str. 9 www.heinrichs.eu</p> <p>CE 0158</p> <hr/> <p>Type: UMC3-B11A41 TAG No.: --- Ser. No.: 123456 MF-Date: 2016/11 Tamb: -20°C to +50°C  Supply: 90-265 V AC / 50/60Hz / 7,5 VA</p> <p> BVS 05 ATEX E 021 X II (1) 2G Ex d [ia Ga] IIB/IIC T6-T3 Gb</p> <hr/> <p>IECEX BVS 11.0094X Ex d [ia Ga] IIB/IIC T6-T3 Gb</p> <hr/> <p>Signal-outputs: Non intrinsically save I-OUT 4-20mA / HART, IMP-OUT, STATUS</p> <hr/> <p>Control unit BE2 II 2G Ex ia IIC T6 Gb Plug in only HEINRICHS transmitter</p> <hr/> <p>Sensor circuits Ex ia IIC / IIB</p> <hr/> <p>← Ex d Terminals</p> <p>WARNING - NOT INTRINSICALLY SAVE CIRCUIT PROTECTED BY INTERNAL IP30 COVER LID. WARNING - DO NOT OPEN EQUIPMENT AT THE PRESENCE OF EXPLOSIVE ATMOSPHERE. SEAL AT THE WALL OF ENCLOSURE.</p> <p style="text-align: right;">Ex d Compartment →</p> <hr/> <p>Cable fittings M20 x 1,5</p> </div>



4.2.2 Ignition category of the transmitter

The transmitter is mounted in an enclosure containing an internal partition, which is divided into an electronics compartment and a terminal connection compartment with an Ex-d "flameproof enclosure" type of protection. The terminal compartment can either be designed with type of protection "d" or "e".

The signal outputs can be designed with intrinsic safety "i" type of protection or as non-intrinsically safe signal outputs. All signal outputs are either designed to type of protection "i" or as non-intrinsically safe. A mixture of both is not permitted.

The converter corresponds to category 2 for use in zone 1. The sensor circuits correspond to category 1 "ia" and can be laid into or through Zone 0.

4.2.2.1 Marking when equipped with Ex e or Ex d terminal compartments

Transmitter with protection type		Marking	
Electronic comp.	Flameproof enclosure „d“		II (1)2G Ex d e [ia Ga] IIC/IIB T6..T3 Gb
Terminal comp.	Increased safety „e“		
BE2 Control unit	Intrinsically safe „i“	II 2G	Ex ia IIC T6 Gb
Electronic comp.	Flameproof enclosure „d“		II (1)2G Ex d [ia Ga] IIC/IIB T6..T3 Gb
Terminal comp.	Flameproof enclosure „d“		
BE2 Control unit	Intrinsically safe „i“	II 2G	Ex ia IIC T6 Gb

4.2.3 Terminal compartment

The electrical connections for all electrical circuits are realised in the transmitter terminal compartment, which in all transmitter versions accommodates both intrinsically safe and non-intrinsically safe circuits. The terminal compartment type of protection (Ex e or Ex d) is indicated on the rating plate. The terminals are covered by the IP 30 ingress protection BE2 control unit.

4.2.3.1 Ex e i type of protection terminal compartment

The gap between the terminals for intrinsically safe and non-intrinsically safe circuits is greater than 50 mm. The cable glands and dummy plugs used must comply with an EU type-examination certificate according to IEC 60079-7. The Ingress protection of the cable glands must be compliant with the relevant housing ingress protection.

The compartments lid may only be removed for very brief periods for purposes such as the configuring of the transmitter. When the cover is removed, care should be taken to ensure that no dampness enters the enclosure.

4.2.3.2 Ex d and Ex d / Ex i type of protection terminal compartment

Connecting cables in a type of protection "Ex d" terminal compartment can be installed in one of the two following ways (Refer also to IEC 60079-14/10.3):

- They can be fed directly through approved flameproof cable glands.
- They can be fed through conduits that are specially designed and approved for this purpose. In this case, the conduit seals must be installed in the immediate vicinity of the enclosure.

4.2.3.3 Equipotential bonding

When the sensor is mounted externally (remote mount configuration), equipotential bonding between the sensor and transmitter is to be realized. Terminals are provided on the outside of the sensor and transmitter for this purpose.

4.2.4 Connecting cables

The connecting cables for power supply, signal outputs and sensor circuits must adhere to the requirements of EN 60079-14.



Note

- The connecting cables are to be installed in such a way that they are protected against mechanical damage and unduly high temperatures.
- The external diameters of the connecting cables must be compatible with the thickness range of the cable glands and rubber seals used.
- The cables and cable glands used must be compatible with the type of protection of the junction box being used.
- The dummy plugs used for unused cable glands must be compliant with the type of protection of the housing being used.
- It must be ensured that the cable gland gaskets are correctly seated.

4.2.4.1 Sensor circuits

Compact mounted transmitter UMC3

, the sensor circuits are considered as internal connections and are already wired by the manufacturer. In such an assembly there is no requirement for verification of these intrinsic safe circuits by the operator.

Remote installation of UMC3

The intrinsically safe sensor circuits are brought out from the transmitter via a cable gland with a cable of at least 1 m in length. The length of the cable can be specified and purchased when ordering.

The transmitter is fixed by a bracket to a wall or a pipe.

The sensor cable is to be installed by the operator so that it is protected from tension.

The assignment of the wire colors and the circuits see section 4.1.2.3

4.2.5 Parameters for the UMC3 transmitter

4.2.5.1 Power circuit (terminals L, N and PE)

Nominal voltage		AC	90 to 230	V
Max. voltage	Um	AC	265	V
Nominal voltage		AC	24	V
Max. voltage	Um	AC	30	V
Nominal voltage		DC	19 to 36	V
Max. voltage	Um	DC	36	V

4.2.5.2 Non-intrinsically safe circuits for Type UMC3-****2

Current output 1			(terminals 41 to 42)	
Current output 2			(terminals 43 to 44)	
Binary output 1, passive			(terminals 46 to 47)	
Binary output 1, active			(terminals 45 and 489)	
Binary output 2, passive			(terminals 49 to 50)	
Binary output 3, passive			(terminals 53 to 54)	
Binary output			(terminals 51 to 52)	
Serial interface RS485 Profibus-DP / Modbus			(terminals 37 to 38)	
Voltage	Um	AC/DC	60	V
Max. current of power supply			500	mA

4.2.5.3 Type of protection Ex ia II sensor circuits

Excitation circuit (terminals 9 and 10)

Linear output characteristic				
Voltage	Uo	DC	19,5	V
Current	Io		90	mA
Power	Po		400	mW

with Ex ia IIC type of protection

Max. external inductance	Lo		5	mH
Max. external capacitance	Co		240	nF

with Ex ia IIB type of protection

Max. external inductance	Lo		18	mH
Max. external capacitance	Co		1490	nF

Temperature sensor circuit (terminals 5 to 8)

Voltage	Uo	DC	19,5	V
Current	Io		6.4	mA
Power	Po		31	mW
Linear output characteristic				

with Ex ia IIC type of protection

Max. external inductance	Lo		870	mH
Max. external capacitance	Co		225	nF

with Ex ia IIB type of protection

Max. external inductance	Lo		1000	mH
Max. external capacitance	Co		1475	nF

Sensor circuits (terminals 1 and 2, 3 and 4)

Values for each circuit

Voltage	Uo	DC	19,5	V
Current	Io		25	mA
Power	Po		128	mW
Linear output characteristic				

with Ex ia IIC type of protection

Max. external inductance	Lo		58	mH
Max. external capacitance	Co		154	nF

with Ex ia IIB type of protection

Max. external inductance	Lo		210	mH
Max. external capacitance	Co		1404	nF

4.2.5.4 Signal output circuits

Current output 1 (terminals 11 and 12) and current output 2 (terminals 13 and 14) for type UMC3-**1, level of protection Ex ia**

Voltage	Uo	DC	19,2	V
Current	Io		84	mA
Power	Po		400	mW
linear output characteristic				

with level of protection Ex ia IIC

Max. external inductance	Lo		5	mH
Max. external capacitance	Co		230	nF

with level of protection Ex ia IIB

Max. external inductance	Lo		19,8	mH
Max. external capacitance	Co		1,53	µF

Binary outputs for type UMC3-**1**

Binary output 1	(terminals 16 and 17)
Binary output 2	(terminals 19 and 20) and
Binary output 3	(terminals 33 - 34)

floating opto-coupler output circuits, level of protection Ex ia IIC

Voltage	Ui	DC	30	V
Current	Ii		200	mA
Power	Pi		3	W
Effective internal inductance	Li		0,2	mH
Effective internal capacitance	Ci		20	nF

Binary input (terminals 21 and 22) for type UMC3-**1, level of protection Ex ia**

Linear output characteristic				
Voltage	Uo	DC	30	V
Current	Io		15	Ma
Power	Po		113	mW

with level of protection Ex ia IIC

Max. external inductance	Lo		160	mH
Max. external capacitance	Co		64,8	nF

with level of protection Ex ia IIB

Max. external inductance	Lo		560	mH
Max. external capacitance	Co		558,8	nF

4.2.5.5 Bus Communication circuits

Profibus-PA, Type UMC3-*D***, (terminals 39 – 40) Level of protection Ex ia IIC for use as field device in a fieldbus system in accordance with FISCO model (PTB Bericht PTB-W-53/IEC 60079-28)**

Voltage	Ui	DC	17,5	V
Effective internal inductance	Li			negligible
Effective internal capacitance	Ci		1,2	nF

for connection to an intrinsically safe communication circuit with

Voltage	Ui	DC	32	V
Current	li		280	mA
Power	Pi		2	W
Effective internal inductance	Li			negligible
Effective internal capacitance	Ci		1,2	nF

FOUNDATION-Fieldbus, Type UMC3-*J***, (terminals 55–56) for use as field device in a fieldbus system in accordance with FISCO**

for connection to an intrinsically safe communication circuit

Level of protection Ex ia IIC

Voltage	Ui	DC	24	V
Current	li		250	mA
Effective internal inductance	Li		10	µH
Effective internal capacitance	Ci			negligible

Level of protection Ex ia IIB

Voltage	Ui	DC	17,5	V
Current	li		380	mA
Effective internal inductance	Li		10	µH
Effective internal capacitance	Ci			negligible

Profibus DP - RS485-IS (Type UMC3-*E***, and Modbus Type UMC3-***F***), (terminals 35 and 36), Type of protection Ex ia IIC**

Voltage	Uo	DC	4,1	V
Current	Io		59	mA
Power	Po		61	mW

linear output characteristic for the connection of an intrinsically safe circuit with:

Voltage	Ui	DC	4,5	V
Effective internal inductance	Li			negligible
Effective internal capacitance	Ci			negligible

4.2.6 UMC3 Ambient Temperature Ranges

4.2.6.1 Standard temperature ranges

For the control unit Type BE

The applicable ambient temperature range for the remote mounted control unit BE2 is:

- 40 °C bis + 70 °C

If mounted in the transmitter enclosure, the ambient temperature of the entire device applies.

Integral mount transmitter types:

Type UMC3-A:	UMC3-A***1*	UMC3-A***2*	UMC3-A***4*
Type UMC3-B:	UMC3-B***1*	UMC3-B***2*	UMC3-B***4*

The following table depicts the dependence of maximum process temperature, type of installation (the use of a 100 mm long adapter piece) and temperature class:

Adapter Piece	Process temperature - 20 °C up to	Ambient temperature - 20 °C up to	Temperature class
Without	80 °C	45 °C	T6
Without	100 °C	55 °C	T5
100 mm	130 °C	55 °C	T4
100 mm	150 °C	50 °C	T3



Caution!

The values for the ambient temperature ranges specified in the type examination certificate of the TMx sensors must however be taken into account

Remote mounted transmitter types:

For the remote mounted transmitters;

Type UMC3-C:	UMC3-C***1*	UMC3-C***2*	UMC3-C***4*
Type UMC3-D:	UMC3-D***1*	UMC3-D***2*	UMC3-D***4*
Type UMC3-E:	UMC3-E***1*	UMC3-E***2*	UMC3-E***4*
Type UMC3-F:	UMC3-F***1*	UMC3-F***2*	UMC3-F***4*

the following standard temperature range applies:

Ambient temperature range: -20 °C to +60 °C

Temperature class: T6

4.2.6.2 Extended ambient temperature range

The following models may be ordered with the extended ambient temperature range of **-40 °C to +80 °C**

Integral mounted transmitters

For integral mounted transmitters of the types;

Type UMC3-A:	UMC3-A***5*	UMC3-A***6*
Type UMC3-B:	UMC3-B***5*	UMC3-B***6*

the following table depicts the dependence of maximum process temperature, type of installation (the use of a 100 mm long adapter piece) and temperature class:

Adapter Piece	Process temperature - 20 °C up to	Ambient temperature - 20 °C up to	Temperature class
Without	80 °C	60 °C	T6
Without	80 °C	80 °C	T5
Without	100 °C	75 °C	T5
100 mm	130 °C	55 °C	T4
100 mm	150 °C	50 °C	T3



Caution!

The values for the ambient temperature ranges specified in the type examination certificate of the TMx sensors must however be taken into account

Remote Mounted transmitter:

For remote mounted transmitters of the types;

Type UMC3-C:	UMC3-C***5*	UMC3-C***6*
Type UMC3-D:	UMC3-D***5*	UMC3-D***6*
Type UMC3-E:	UMC3-E***5*	UMC3-E***6*
Type UMC3-F:	UMC3-F***5*	UMC3-F***6*

The ambient temperature range is:

- for the temperature class T6
 - for the temperature class T5
- 40 °C to + 60 °C and
- 40 °C to + 80 °C.

4.3 The Control Unit BE2

In the standard version, the connection terminals of the transmitter are covered by the control unit type BE2 providing the degree of protection IP30. For this reason, the threaded enclosure lid of the terminal compartment may be opened when the operating voltage is switched on even in an Ex area. The parameters of the transmitter can be configured during operation via the BE2.

Thereby, the following requirements must be observed



Caution

- The threaded lid of the terminal compartment may only be opened briefly during operation to configure the converter. Particular care must be taken to ensure that no moisture penetrates the connection housing.
- If the terminal compartment is designed with type of protection "d", the screw cover may only be opened if there is no explosive atmosphere present.

In principle, different transmitters of a device family can be configured with just one control unit BE2. The connection cable of the BE2 is pluggable. If no local display is required, several transmitters can be configured with one BE2. In order to allow the converter to be opened without a built-in BE2, but also under voltage, the connection terminals must be covered. This is achieved by means of a special cover plate on which there is a plug for connecting the BE2. In the Ex version, the circuit for operating the BE2 is designed with intrinsic safety "Ex i" type of protection and can therefore also be switched on and off in the Ex area.

4.3.1 Connection of the converter during commissioning

The threaded lid of the terminal compartment is unscrewed. Then the cover plate of the connection terminals is loosened and removed. The screws are permanently attached to the cover plate so cannot fall out. On the underside of the cover plate there is a cable with a plug, which is located in the plug for a built-in BE2. This connection can be detached if required.

After connecting the supply and signal lines, the plug of the cable is plugged back into the cover plate in the position for the original connection of the BE. The cover plate is now reinserted and screwed into position and the enclosure is closed with the threaded lid.

4.3.2 Procedure for Configuration

The threaded lid of the enclosures terminal compartment is unscrewed. The terminal cover plate can now be seen on which the connector for connecting the BE2 is located. After plugging in the BE2, it is automatically initialized and the following messages appear on the display one after the other:

- Type of BE unit and Software revision
- The connected transmitter type (e.g. UMC3)
- The data selection that was last set for the converter under the sub-menu "Display when switching on".

The transmitter can now be configured according to the operating instructions.

After configuration, the connector is simply removed and the threaded lid is carefully screwed back onto the enclosure.

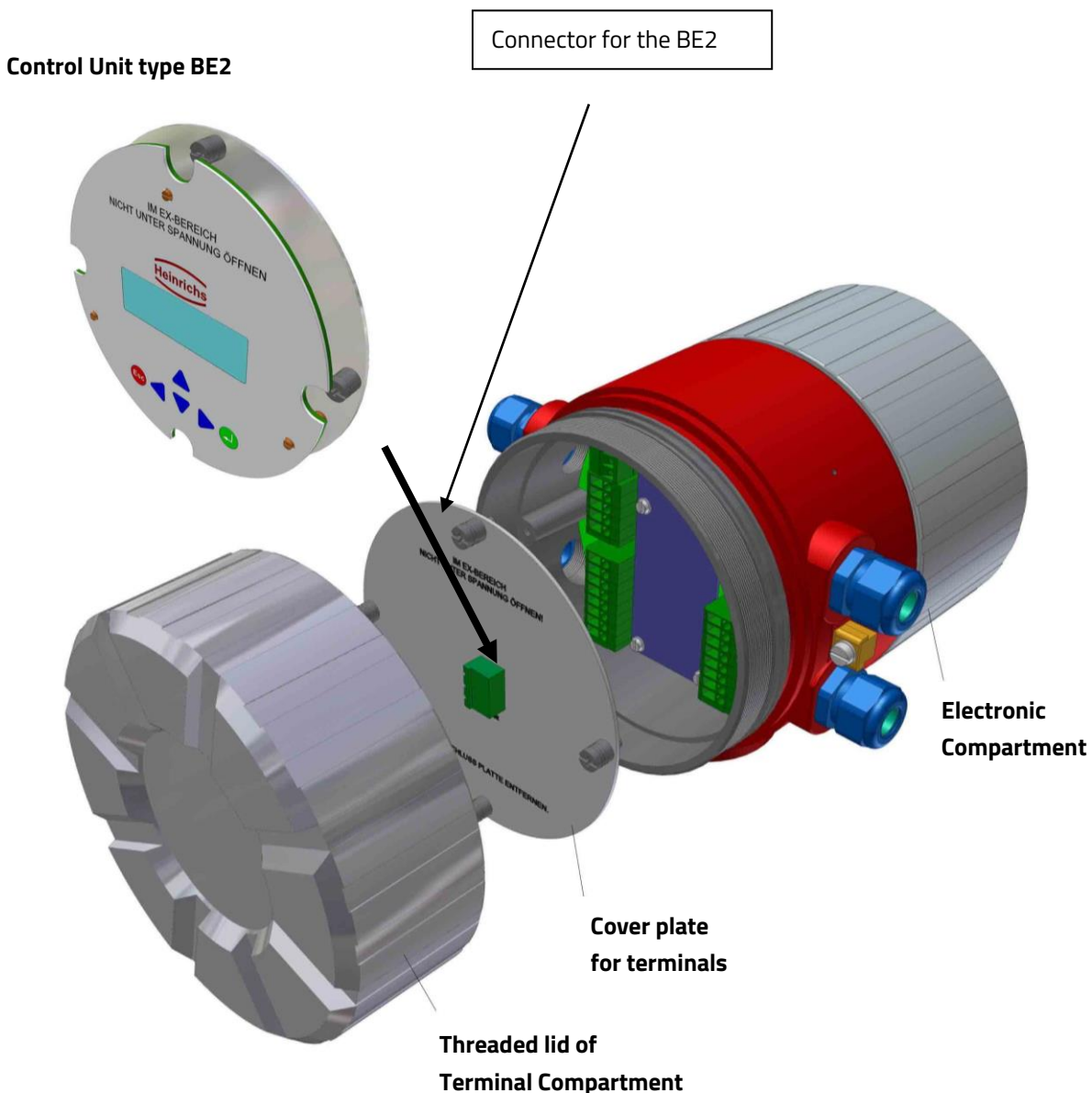

5. Installation and Commissioning

The mounting instructions for the standard sensor also apply to the explosion-proof sensor.

Depending on the approval of the connected transmitter, the sensor may either be:

- Compact mounted, mechanically fastened to the transmitter presenting a single unit.
or
- Remotely installed and connected with a special sensor cable.

5.1 Special conditions for safe use for the UMC3

- For the electrical connections, specially certified cable entries and/or plugs are to be used in accordance with the prevailing type of protection and ambient temperature. Furthermore, the connection cable used must be suitable for the prevailing ambient temperature range.
- When conduit entries are connected to the transmitter enclosure, they must be certified for this purpose and the associated stopping boxes must be mounted in the immediately vicinity of the enclosure.
- Integral mounted transmitters are designed with intrinsically safe sensor circuits. All electrical relevant values are coordinated by Heinrichs Messtechnik and not important for the user.
- a) When using a connection cable other than the manufacturer's specified cable, the suitability of the cable are to be validated using the cable's nominal parameters:

Cable capacitance	100 pF/m
Cable inductance	0.7 µH/m
- For transmitters with the sensor cable, the cable must be installed in such a way that tensile force is omitted.
- **Damaged threaded or flat joints which may impair the IP protection of the enclosure shall not be repaired or modified!** The equipment shall be returned to the manufacturer for repair and replacement.

5.2 General conditions for safe operation

- a) If the conditions described in this document are not adhered to or if there is any inappropriate interference with the equipment, the manufacturer's warranties expire.
- b) Conditions described in this manual, as well as the permitted operating conditions which have been defined for the sensor and which are stated on the rating plates must be adhered to.
- c) Appropriate measures shall be met to prevent any unintentional or inadmissible damage to the device.
- d) The operator shall ensure that the equipment is only installed in areas which comply with the approved types of protection and environments.
- e) All connected electrical equipment must be suitable for its intended use.
- f) The operator shall ensure protection against lightning according to local regulations
- g) The danger of objects falling onto the sensor shall be excluded
- h) The maximum process temperature of 260 °C is only permitted for periods of maximum 1 hour, for example during the ramping up of the process temperature, or temperature regulation. Prolonged

operation at temperatures above 220 °C may lead to an accelerated deterioration insulation materials and thus a reduction in the sensors life span.

5.3 Requirements for installation in all environments

- a) The installation of the intrinsically safe circuits requires a control drawing (system description), to be issued by the operator/erector.
- b) The equipment is only to be installed and connected in a de-energized state.
- c) The sensor is to be installed (from specialists) according to applicable regulations.
- d) When mounted separately (remote mount configuration), equipotential bonding between the sensor and transmitter must be ensured
- e) It is to be insured that the intrinsically safe circuits of the sensor cable are not laid together with non-intrinsically safe circuits.
- f) If the sensor is used at an ambient temperature of less than -20 °C or greater 60 °C, suitable cables, cable entries and conduit entries are to be used.
- g) The operational wall thickness of the stainless steel flow tubes may be < 1 mm. In this case, the operator is to ensure that in the area of these tubes, no risk of damage by the process medium or through mechanical influence shall occur.
- h) Although the measuring tubes are in constant oscillation, the deflection of this oscillation is significantly smaller (< 1 mm) than the materials stress levels allow and thus presents no addition requirements for protective measures.
- i) The sensor may be used in such a way that in the measuring tubes an explosive atmosphere may be present occasionally or for a long period of time.
- j) Seized screws or adhering joints (e.g. by frost or corrosion) are not to be opened with force when the presence of a potentially explosive atmosphere is considered possible.
- k) Where substances of explosion group "A" or "IIC" are present and the presence of an Ex-atmosphere is considered possible, only non-sparking tools shall be used.
- l) The electrical connections from the sensor to the junction box are made by means of a connection flange. Care must be taken to guarantee the IP protection class.

5.4 Ex relevant screw and bolt torques

Potential Equalisation fixation	6 Nm
Nuts sensor-neck/J-box	6 Nm
Screws J-box lid (Aluminium)	2 Nm
Screws J-box lid (Polyester)	1.2 Nm
Cable glands to J-box adapter	12 Nm
Cable gland caps	8 Nm

6. Maintenance and repair work

6.1 Definition of terms according to IEC 60079-17:

Maintenance: defines a combination of any actions carried out to retain an item in, or restore it to, conditions in which it is able to meet the requirements of the relevant specification and perform its required functions.

Inspection: defines any action comprising careful scrutiny of an item carried out either without dismantling, or with the addition of partial dismantling as required, supplemented by means such as measurement, in order to arrive at reliable conclusion as to the condition of an item.

Visual inspection: defines an inspection which identifies, without the use of access equipment and tools, those defects, such as missing bolts, which will be apparent to the eye.

Close inspection: defines an inspection which encompasses those aspects covered by a visual inspection and, in addition, identifies those defects, such as loose bolts, which will be apparent only by the use of access equipment, for example steps, where necessary, and tools.

Detailed inspection: defines an inspection which encompasses those aspects covered by a close inspection and, in addition, identifies those defects, such as loose terminations, which will only be apparent by opening the enclosure, and/or using, where necessary, tools and test equipment.

- a) Maintenance or replacement work must be carried out by qualified personnel only, i.e. personnel qualified according to TRBS 1203 or similar.
- b) Only auxiliary components which comply with all European and national directives and legislations may be used in potentially explosive atmospheres
- c) After maintenance and repair works have been performed, all barriers and notices removed for that purpose must be returned to their original place.
- d) In the event that faults of the equipment are detected, the equipment is to be removed. The internal components cannot be repaired by the customer. The equipment is to be returned to the manufacturer for inspection.
- e) With the exception of the replaceable mains fuse, fuses may **not** be replaced by the operator, since affected Zener-diodes must also be simultaneously replaced. This work requires a follow-up adjustment, which can only be carried out at the manufacturer's factory.

6.2 Recommended inspection intervals

Activity		Visual inspection	Close inspection	Detailed inspection
		3 month interval	6 month interval	12 month interval
1	Visual inspection of equipment for intactness, removal of dust settlements	X		
2	Check of electrical system for intactness and functionality			X
3	Check of entire system		User's responsibility	

7. Warning notices

- The thread of the cable gland entry is noted on the rating plate
- The exciter circuit type as specified in the certificates is noted on the rated plate
- The following warnings or similar wordings are either printed on the rating plate, or are stated in the User Manual:

“Substitution of components may impair intrinsic safety”

“Do not open when energized or when an explosive atmosphere is present”

- The following warning or similar wording is printed on the plastic cover of the TME sensor body:

Caution! Electrostatic charging possible; To be considered during cleaning and maintenance work.

8. Model codes

8.1 The Transmitter UMC3

UMC3	-	A	B	C	D	E	F
------	---	---	---	---	---	---	---

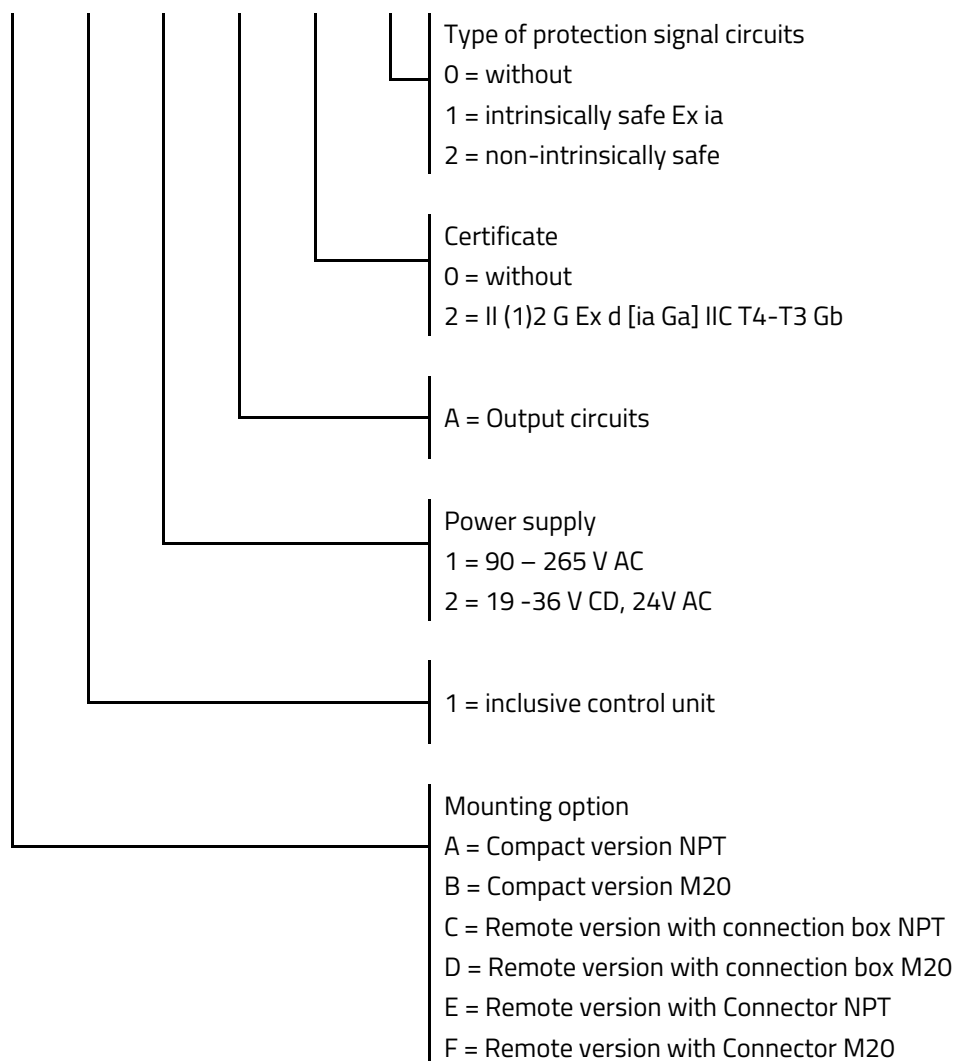

8.2 The TM Sensor

TM-	A	B	C	-	D	E	F	G	H	I	J	K	-	L	M	N	O	-	P	-	Q	-	R	-	S
-----	---	---	---	---	---	---	---	---	---	---	---	---	---	---	---	---	---	---	---	---	---	---	---	---	---

Pos.	Description	Remarks / EX-Relevance
A	Wetted Material	Non-Ex relevant position
B,C	Flow-Rate Range	Non-Ex relevant position
D,E,F,G	Process Connection	Non-Ex relevant position
H,I,J,K	Installation Length	Non-Ex relevant position
L	Enclosure Options	Non-Ex relevant position
M	Heating / Cooling	Non-Ex relevant position
N	Flow Direction	Non-Ex relevant position
O	Sensor configurations	
(*2) (*3)	1 - Mounted -50°C to 100°C (-58°F to 212°F)	Refer to Transmitter approval
	2 - Mounted -50°C to 150°C (-58°F to 302°F)	Refer to Transmitter approval
	3 - Remote -50°C to 100°C (-58°F to 212°F)	with M20 x 1.5 mm Cable gland (AI)
	4 - Remote -50°C to 180°C (-58°F to 356°F)	with M20 x 1.5 mm Cable gland (AI)
	5 - Remote -50°C to 220/260°C (-58°F to 500°F)	with M20 x 1.5 mm Cable gland (AI)
	6 - Remote -50°C to 100°C (-58°F to 212°F)	with ½" NPT Cable gland
	7 - Remote -50°C to 180°C (-58°F to 356°F)	with ½" NPT Cable gland
	8 - Remote -50°C to 220/260°C (-58°F to 500°F)	with ½" NPT Cable gland
	S- Remote -50°C to 100°C (-58°F to 212°F)	with M20 x 1.5 mm Cable gland (PE)
	T - Remote -50°C to 180°C (-58°F to 356°F)	with M20 x 1.5 mm Cable gland (PE)
	U - Remote -50°C to 220/260°C (-58°F to 500°F)	with M20 x 1.5 mm Cable gland (PE)
P (*1)	Approvals	
	A - ATEX / IECEx – up to Supplement 6	II 1/2G Ex ia IIC T2...T6 Ga/Gb
	L - ATEX / IECEx – Supplement 7 onwards	II 1/2G Ex ia IIC T2...T6 Ga/Gb
Q	Certificates	Non-Ex relevant position
R	Supplementary equipment	Non-Ex relevant position
S,T,U,V	Additional Options	Non-Ex relevant position

(*1) = After implementation of ATEX supplement 7 (IEC issue 1), sensors of supplement 6 (IEC issue 0) with the code „A“ shall no longer be produced, and are therefore no longer available for delivery.

(*2) = The Abbreviations AI and PE determine whether an aluminium (AI) or polyester (PE) terminal box is mounted.

(*3) = The maximum process temperature of 260 °C is only permitted short-term. Refer to section 5.2 for more details

8.3 The TMU Sensor

TMU-	A	B	C	D	-	E	F	G	H	-	I	J	K	-	L	M	-	N	O	-	P	-	Q
------	---	---	---	---	---	---	---	---	---	---	---	---	---	---	---	---	---	---	---	---	---	---	---

Pos.	Description	Remarks / EX-Relevance
A	Wetted Material	Non-Ex relevant position
B,C,D	Model size	Non-Ex relevant position
E,F,G,H	Process Connection	Non-Ex relevant position
I	Enclosure Options	Non-Ex relevant position
J	Heating / Cooling	Non-Ex relevant position
K	Heating / Cooling connections	Non-Ex relevant position
L	Sensor configurations	
(*2) (*3)	A - Mounted -50°C to 100°C (-58°F to 212°F)	Refer to Transmitter approval
	B - Mounted -50°C to 150°C (-58°F to 302°F)	Refer to Transmitter approval
	C - Remote -50°C to 100°C (-58°F to 212°F)	with ½" NPT Cable gland (AI)
	D - Remote -50°C to 180°C (-58°F to 356°F)	with ½" NPT Cable gland (AI)
	E - Remote -50°C to 220/260°C (-58°F to 500°F)	with ½" NPT Cable gland (AI)
	F - Remote -50°C to 100°C (-58°F to 212°F)	with M20 x 1.5 mm Cable gland (AI)
	G - Remote -50°C to 180°C (-58°F to 356°F)	with M20 x 1.5 mm Cable gland (AI)
	H - Remote -50°C to 220/260°C (-58°F to 500°F)	with M20 x 1.5 mm Cable gland (AI)
	K - Remote -50°C to 100°C (-58°F to 212°F)	with HAN R23 Connector
	L - Remote -50°C to 180°C (-58°F to 356°F)	with HAN R23 Connector
	M - Remote -50°C to 220/260°C (-58°F to 500°F)	with HAN R23 Connector
	S- Remote -50°C to 100°C (-58°F to 212°F)	with M20 x 1.5 mm Cable gland (PE)
	T - Remote -50°C to 180°C (-58°F to 356°F)	with M20 x 1.5 mm Cable gland (PE)
	U - Remote -50°C to 220/260°C (-58°F to 500°F)	with M20 x 1.5 mm Cable gland (PE)
	X - Customer specified	
M	Approvals	
(*1)	A - ATEX / IECEx – up to Supplement 6	II 1/2G Ex ia IIC T2...T6 Ga/Gb
	L - ATEX / IECEx – Supplement 7 onwards	II 1/2G Ex ia IIC T2...T6 Ga/Gb
N	Calibration Flow	Non-Ex relevant position
O	Calibration Density	Non-Ex relevant position
P	Supplementary Equipment	Non-Ex relevant position
Q	Design	Non-Ex relevant position

(*1) = After implementation of ATEX supplement 7 (IEC issue 1), sensors of supplement 6 (IEC issue 0) with the code „A“ shall no longer be produced, and are therefore no longer available for delivery.

(*2) = The Abbreviations AI and PE determine whether an aluminium (AI) or polyester (PE) terminal box is mounted.

(*3) = The maximum process temperature of 260 °C is only permitted short-term. Refer to section 5.2 for more details

8.4 The TME Sensor

TME -	A	B	C	-	D	E	F	G	H	I	J	-	K	-	L	-	M	-	N
-------	---	---	---	---	---	---	---	---	---	---	---	---	---	---	---	---	---	---	---

Pos.	Description	Remarks / EX-Relevance
A	Wetted Material	Non-Ex relevant position
B,C	Flow-Rate Range	Non-Ex relevant position
D,E,F,G	Process Connection	Non-Ex relevant position
H	Heating / Cooling	Non-Ex relevant position
I	Flow Direction	Non-Ex relevant position
J	Sensor configurations	
(*2)	1 - Mounted -50°C to 100°C (-58°F to 212°F)	Refer to Transmitter approval
	2 - Mounted -50°C to 150°C (-58°F to 302°F)	Refer to Transmitter approval
	3 - Remote -50°C to 100°C (-58°F to 212°F)	with M20 x 1.5 mm Cable gland (AI)
	4 - Remote -50°C to 180°C (-58°F to 356°F)	with M20 x 1.5 mm Cable gland (AI)
	6 - Remote -50°C to 100°C (-58°F to 212°F)	with ½" NPT Cable gland
	7 - Remote -50°C to 180°C (-58°F to 356°F)	with ½" NPT Cable gland
	S- Remote -50°C to 100°C (-58°F to 212°F)	with M20 x 1.5 mm Cable gland (PE)
	T - Remote -50°C to 180°C (-58°F to 356°F)	with M20 x 1.5 mm Cable gland (PE)
K (*1)	Approvals	
	A - ATEX / IECEx – up to Supplement 6	II 1/2G Ex ia IIC T2...T6 Ga/Gb
	L - ATEX / IECEx – Supplement 7 onwards	II 1/2G Ex ia IIC T2...T6 Ga/Gb
L	Certificates	Non-Ex relevant position
M	Supplementary equipment	Non-Ex relevant position
N	Design	Non-Ex relevant position

(*1) = After implementation of ATEX supplement 7 (IEC issue 1), sensors of supplement 6 (IEC issue 0) with the code „A“ shall no longer be produced, and are therefore no longer available for delivery.

(*2) = The Abbreviations AI and PE determine whether an aluminium (AI) or polyester (PE) terminal box is mounted.

8.5 The TMR Sensor

TMR -	A	B	C	-	D	E	F	G	H	I	J	K	-	L	M	N	O	-	P	-	Q	-	R
-------	---	---	---	---	---	---	---	---	---	---	---	---	---	---	---	---	---	---	---	---	---	---	---

Pos.	Description	Remarks / EX-Relevance
A	Wetted Material	Non-Ex relevant position
B,C	Flow-Rate Range	Non-Ex relevant position
D,E,F,G	Process Connection	Non-Ex relevant position
H,I,J,K	Installation Length	Non-Ex relevant position
L	Enclosure Options	Non-Ex relevant position
M	Heating / Cooling	Non-Ex relevant position
N	Flow Direction	Non-Ex relevant position
O	Sensor configurations	
(*2) (*3)	1 - Mounted -50°C to 100°C (-58°C to 212°F)	Refer to Transmitter approval
	2 - Mounted -50°C to 150°C (-58°F to 302°F)	Refer to Transmitter approval
	3 - Remote -50°C to 100°C (-58°F to 212°F)	with M20 x 1.5 mm Cable gland (AI)
	4 - Remote -50°C to 180°C (-58°F to 356°F)	with M20 x 1.5 mm Cable gland (AI)
	5 - Remote -50°C to 220/260°C (-58°F to 500°F)	with M20 x 1.5 mm Cable gland (AI)
	6 - Remote -50°C to 100°C (-58°F to 212°F)	with ½" NPT Cable gland
	7 - Remote -50°C to 180°C (-58°F to 356°F)	with ½" NPT Cable gland
	8 - Remote -50°C to 220/260°C (-58°F to 500°F)	with ½" NPT Cable gland
	S- Remote -50°C to 100°C (-58°F to 212°F)	with M20 x 1.5 mm Cable gland (PE)
	T - Remote -50°C to 180°C (-58°F to 356°F)	with M20 x 1.5 mm Cable gland (PE)
	U - Remote -50°C to 220/260°C (-58°F to 500°F)	with M20 x 1.5 mm Cable gland (PE)
P (*1)	Approvals	
	A - ATEX / IECEx – up to Supplement 6	II 1/2G Ex ia IIC T2...T6 Ga/Gb
	L - ATEX / IECEx – Supplement 7 onwards	II 1/2G Ex ia IIC T2...T6 Ga/Gb
Q	Certificates	Non-Ex relevant position
R	Supplementary equipment	Non-Ex relevant position

(*1) = After implementation of ATEX supplement 7 (IEC issue 1), sensors of supplement 6 (IEC issue 0) with the code „A“ shall no longer be produced, and are therefore no longer available for delivery.

(*2) = The Abbreviations AI and PE determine whether an aluminium (AI) or polyester (PE) terminal box is mounted.

(*3) = The maximum process temperature of 260 °C is only permitted short-term. Refer to section 5.2 for more details

8.6 The TM-SH Sensor

TM-SH -	A	B	C	D	-	E	F	G	H	-	I	J	K	-	L	M	-	N	O	-	P	-	Q
---------	---	---	---	---	---	---	---	---	---	---	---	---	---	---	---	---	---	---	---	---	---	---	---

Pos.	Description	Remarks / EX-Relevance
A,B	Model / Range	Non-Ex relevant position
C,D	Wetted Material	Non-Ex relevant position
E,F,G,H	Process Connection	Non-Ex relevant position
I	Enclosure Options	Non-Ex relevant position
J	Enclosure Filling	Non-Ex relevant position
K	Heater / cooling	Non-Ex relevant position
L	Sensor configurations	
	K - Remote -50°C to 60°C (-58°F to 140°F)	Connection via M20 1,5 connector
	L - Remote -50°C to 100°C (-58°F to 212°F)	Connection via M20 1,5 connector
	X - Customer specified	Connection via M20 1,5 connector
M (*1)	Approvals	
	A - ATEX / IECEx – up to Supplement 6	II 1/2G Ex ia IIC T2...T6 Ga/Gb
	L - ATEX / IECEx – Supplement 7 onwards	II 1/2G Ex ia IIC T2...T6 Ga/Gb
N	Calibration Flow	Non-Ex relevant position
O	Calibration Density	Non-Ex relevant position
P	Supplementary Equipment	Non-Ex relevant position
Q	Design	Non-Ex relevant position

(*1) = After implementation of ATEX supplement 7 (IEC issue 1), sensors of supplement 6 (IEC issue 0) with the code „A“ shall no longer be produced, and are therefore no longer available for delivery

9. EC Declaration of conformity



EU-Konformitätserklärung
EU-Declaration of Conformity



Nº. 20-4120-01

Hersteller:
Manufacturer: Heinrichs Messtechnik GmbH
Robert-Perthel-Strasse 9
50739 Köln

Produktbeschreibung:
Product description: **Coriolis Durchflussmessgerät UMC3 für Verwendung mit der Sensorreihe TM***
Coriolis Flowmeter UMC3 for use with the Sensor series TM*

Hiermit erklären wir, in alleinige Verantwortung, dass das oben genannte Messsystem den Anforderungen der folgenden EU-Richtlinien, einschließlich allen bis heute veröffentlichten Änderungen bzw. Nachträgen entspricht:

We declare herewith, in sole responsibility, that the product described above is conform with the provisions of the following EU-directives, including all published changes and amendments as of today:

- | | |
|--------------------------|--|
| 2014/30/EU (EMC) | EU-Richtlinie über die Elektromagnetische Verträglichkeit
<i>EU-Directive relating to electromagnetic compatibility</i> |
| 2014/34/EU (ATEX) | EU-Richtlinie über Geräte zur Bestimmungsgemäße Verwendung in explosionsgefährdeten Bereichen.
<i>EU-Directive relating to electrical equipment intended for use in potentially explosive atmospheres</i> |
| 2014/35/EU (LVD) | EU-Richtlinie über die Bereitstellung elektrischer Betriebsmittel zur Verwendung innerhalb bestimmter Spannungsgrenzen auf dem Markt
<i>EU-Directive relating to the making available on the market of electrical equipment designed for use within certain voltage limits</i> |
| 2014/68/EU (PED) | EU-Richtlinie zur Harmonisierung der Rechtsvorschriften der Mitgliedstaaten über die Bereitstellung von Druckgeräten auf dem Markt
<i>EU-Directive on the harmonisation of the laws of the Member States relating to the making available on the market of pressure equipment</i> |

Anhang N und X sind ein integraler Bestandteil dieser Erklärung
Annex N and X are an integral part of this declaration

Köln, den 01.04.2020



Joseph Burke
(Explosionsschutzbeauftragter /
Explosion Protection Representative)



Michael Manderfeld
(Druckgerätebeauftragter /
PED Representative)



Guido Thometzki
(Geschäftsführung / Managing Director)

Kontakt: Tel: +49 (221) 49708-0
Contact: Email: info@heinrichs.eu
Web: www.heinrichs.eu

Konformitätserklärung-UMC3_20-4120-01.docx

Seite 1 von 3

**CE Anhang N zur EU-Konformitätserklärung
Annex N of the EU-Declaration of Conformity**



Nº. 20-4120-01

Produktbeschreibung: **Coriolis Durchflussmessgerät UMC3 für Verwendung mit der Sensorreihe TM***
 Product description: **Coriolis Flowmeter UMC3 for use with the Sensor series TM***

Die Konformität mit den auf Seite 1 genannten Richtlinien diese Erklärung wird nachgewiesen durch die Einhaltung folgenden Normen (abhängig von Gerätvariant):
 Conformity to the Directives referred to on Page 1 of this Declaration is assured through the application of the following standards (depending on version of device):

Richtlinie Direktive	Norm –Ref. Nr. Standard / Ref. Nº.	Ausgabe Edition	Norm Beschreibung Standard Description	UMC3	Bedieneinheit BE-2	TM/ TMU/ TME/ TMR	TM-SH
	DIN EN -						
2014/30/EU	61000-6-2	2011-06	Immunity Industrial enviroment	X	X		
	61000-6-3	2012-11	Emission residential enviroment	X	X		
	55011	2011-04	Radio frequency disturbance	X	X		
	61326-1	2011-07	EMC requirements	X	X		
2014/34/EU	60079-0	2012+A11	General requirements	X	X	X	X
	60079-1	2014	Flameproof Enclose „d“	X			
	60079-7	2015	Increased Safety „e“	X			
	60079-11	2012	Intrinsic Safety „i“	X	X	X	X
	60079-26	2015	Protection Level (EPL) „Ga“			X	X
2014/35/EU	61010	2011-07	Safety requirements	X	X	X	X
2014/68/EU	AD 2000-Merkblätter		Module H			X	X

X: Zutreffende Norm / Applicable Standard

Name und Anschrift der Notifizierte Stelle / Name and Address of the Notified Body

TÜV-SÜD Industrie Service GmbH
 TÜV SÜD Gruppe
 Westendstraße 199
 D-80686 München
 ID-Nr. / ID-Nº.: RL 2014/68/EU: 0036

DEKRA Testing and Certification GmbH
 Carl-Beyling-Haus
 Dinnendahlstraße 9
 D-44809 Bochum
 ID-Nr. / ID-Nº.: RL 2014/34/EU: 0158



CE Anhang X zur EU-Konformitätserklärung
Annex X of the EU-Declaration of Conformity



Nº. 20-4120-01

Produktbeschreibung: **Coriolis Durchflussmessgerät UMC3 für Verwendung mit der Sensorreihe TM***
Product description: **Coriolis Flowmeter UMC3 for use with the Sensor series TM***

Gerät Zulassungen / Device certification

EG-Baumusterprüfbescheinigung EC-type examination certificate	Nachtrag Supplement	Kennzeichnung Marking	UMC3	BE-2	TM/TMU/ TME/TMR	TM-SH
BVS 05 ATEX E 021 X	3	II (1) 2G	X			
		II 2G		X		
DMT 01 ATEX E 149 X	7	II 1/2G			X	X

X: Zutreffende Norm / Applicable Standard

Die oben genannten Produkte entsprechen der Richtlinie 2014/34/EU. Neue Editionen können bereits eine oder mehrere der in den jeweiligen EG-Baumusterprüfbescheinigungen genannten Normen ersetzt haben. Der Hersteller erklärt, dass alle Produkte erwähnt in dieser Konformitätserklärung auch der Anforderungen der neuen Editionen einhalten, weil die veränderten Anforderungen der neuen Editionen entweder keinen Einfluss auf das Produkt haben, oder das Produkt die Anforderungen erfüllt.

The above-mentioned products comply with the Directive 2014/34/EU. New editions may have already replaced one or more of the Standards stated in the respective EC-Type-examination certificates. The manufacturer declares that all products mentioned in this Declaration of Conformity also comply with the requirements of the new editions since either the changed requirements of the new editions do not affect the product, or the product also fulfills the requirements.

Heinrichs Messtechnik GmbH

Robert-Perthel-Straße 9
50739 Köln
Telefon 0221/49708-0
Telefax 0221/49708-178
<http://www.heinrichs.eu>
info@heinrichs.eu

Bankverbindung

Dresdner Bank Köln
BLZ 370 800 40
Konto-Nr. 0955 051300
IBAN :
DE58 3708 0040 0955 0513 00
SWIFT-BIC: DRES DE FF 370

Erfüllungsort und Gerichtsstand:

Köln
Amtsgericht Köln HRA 37040

Ust.IDNr.: DE813416533
Steuer-Nr.: 217/5743/0386

Geschäftsführer

Dipl. Ing. (FH)
Guido Thometzki