Magnetic Inductive Flowmeter

EP

Installation and Operating Instructions

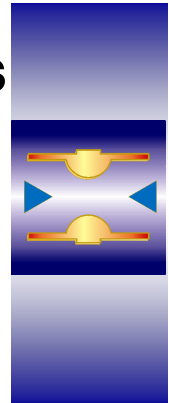

Table of contents

1	SAFETY ADVISORIES	4
1.1	Installation, commissioning, operating personnel.....	4
1.2	Intended purpose.....	4
1.3	Packaging, storing, transport.....	4
1.4	Returning the device for repair and servicing	4
2	IDENTIFICATION	5
2.1	Supplier/manufacturer.....	5
2.2	Product type	5
2.3	Product name	5
2.4	Issue date	5
2.5	Version no.	5
2.6	Designation/rating plate	5
3	APPLICATIONS	6
4	OPERATIONAL MODE AND SYSTEM DESIGN	6
4.1	Operational mode	6
4.2	System design.....	6
4.2.1	Integral mount transmitter.....	7
4.2.2	Remote mount transmitter	7
5	PERFORMANCE CHARACTERISTICS	8
5.1	Measuring accuracy	8
5.1.1	Measured error	8
5.1.2	Repeatability	8
5.1.3	Reference conditions	8
5.2	Fluid conductivity	8
5.3	Influence of ambient temperature	8
5.4	Influence of fluid temperature	8
5.5	Materials	9
5.5.1	Wetted parts	9
5.5.2	Non-wetted parts	9
6	INSTALLATION/CONDITIONS FOR USE	9
6.1	Receipt of goods and transport	9
6.1.1	Receipt of goods.....	9
6.1.2	Transport	9
6.2	Installation conditions.....	10
6.2.1	Long pipe systems.....	10
6.2.2	Pumps.....	10
6.2.3	Bypass	10
6.2.4	Flow tube lining.....	10
6.3	Installation	11
6.3.1	Installation in pipes with larger nominal sizes	11
6.3.2	Horizontal and vertical installation	11
6.3.3	Installation examples	12
6.3.4	Grounding	13
6.3.5	Torques for screws and bolts	15
6.3.6	Remote mount transmitter	16
6.4	Wiring.....	16

6.4.1	Integral mount transmitter.....	17
6.4.2	Remote mount transmitter type UMF2 (B)	17
6.5	Nominal size and ranges.....	18
6.6	Ambient conditions	19
6.6.1	Ambient temperature range.....	19
6.6.2	Storage temperature range	20
6.6.3	Climatic category	20
6.6.4	Ingress protection	20
6.6.5	Shock resistance/vibration resistance	20
6.7	Process pressure.....	21
6.8	Fluid temperature.....	21
7	DIMENSIONS AND WEIGHTS	22
7.1	Dimension drawing of EP-***: DN 10 to DN 1200, flange version	22
7.2	Dimensions of flangeless version.....	23
7.3	Dimensions of food connection DIN 11851.....	24
7.4	Dimensions of connection Tri-Clamp®	24
7.5	Transmitter type UMF2 (B).....	25
7.5.1	Integral mount transmitter.....	25
7.5.2	Sensor terminal box – remote mount transmitter	25
7.5.3	Wall mounting	26
7.5.4	Pipe mounting – vertical position.....	26
7.5.5	Pipe mounting – horizontal position	26
7.6	Dimension drawing: grounding rings.....	27
8	MAINTENANCE	28
9	AUXILIARY POWER, ELECTRICAL CONNECTION	28
10	CE MARK	28
11	STANDARDS AND DIRECTIVES, CERTIFICATES AND APPROVALS.....	28
12	DECLARATION OF CONFORMITY FEHLER! TEXTMARKE NICHT DEFINIERT.	
13	DECONTAMINATION CERTIFICATE FOR DEVICE CLEANING	30

Introduction

This installation and operating manual explains how to operate, install and perform maintenance on the flowmeter. Please read the manual carefully before installing the device and putting it into operation. The manual does not apply to non-standard versions or applications.

All devices are thoroughly tested and checked for order compliance prior to shipping. Upon receipt of the device, check it for shipping damage.

If any problem comes to light, contact our head office in Cologne. Please describe the problem and indicate type and serial number of the device. We extend no guarantee of any kind for repair work that is undertaken without notifying us in advance of the intention to carry out such work. Unless otherwise agreed, any part or component for which a claim is lodged is to be sent to us for examination.

1 Safety advisories

1.1 Installation, commissioning, operating personnel



Mechanical and electrical installation, as well as commissioning, maintenance and operation, are to be realized solely by qualified personnel that are authorized by the installation operator to perform such work. All such personnel must read and understand the content of the applicable operating instructions before working with the device.

In general, follow the conditions and provisions applicable in your country.

Please take note of the technical data on the rating plate and the safety advisories in the Operating Instructions of the corresponding transmitter!

1.2 Intended purpose

The electromagnetic flowmeter is to be used solely for measuring the volume flow of liquids, suspensions and pastes with conductivity $\geq 5 \mu\text{S}/\text{cm}$ ($\geq 20 \mu\text{S}/\text{cm}$ demineralized cold water). The manufacturer accepts no responsibility for any damage or loss resulting from any other use or from improper use. Heinrichs Messtechnik extends no express or implied warranty in regard to the applicability of the present document for any purpose other than that described herein.

Before using corrosive or abrasive fluids, the operator must test the resistance of all wetted materials. We will be happy to assist you in testing the corrosion resistance of wetted parts (for special fluids including cleaning fluids). However, sole responsibility for ensuring that the device is used in accordance with the manufacturer's recommendations rests with the system operator. Minor changes of temperature, concentration or the degree of contamination in the process may cause changes in corrosion resistance. The manufacturer accepts no responsibility for any damage with respect to corrosion resistance of wetted materials in a certain application.

1.3 Packaging / storage / transport

Be careful not to damage the device while unpacking it. The device should be stored in a clean, dry room until it is installed so as to prevent particulate matter from entering the device. Make certain that the ambient temperature in the room in which the device is stored lies within the prescribed range.

Check to ensure that the technical product data indicated on the delivery note is consistent with the stipulated requirements. If, after the device is unpacked, it is sent elsewhere to be installed, the original packaging and transport protection inserts should be used.

1.4 Returning the device for repair and servicing

Note: According to German waste disposal legislation, it is the owner's or customer's responsibility to dispose of hazardous waste. Thus, any devices sent to us for servicing, including their crevices and cavities, must be devoid of any such material.

When sending a device for repair, please confirm your compliance with this regulation in writing. In the event any hazardous material is detected on or inside any device sent to us for servicing, we reserve the right to bill the customer for the cost of disposing of such material (see Section 13 "**Decontamination certificate**").

2 Identification

2.1 Supplier/manufacturer

Heinrichs Messtechnik GmbH
 Robert-Perthel-Str. 9 · D-50739 Köln
 Telephone: +49 221 49708 – 0, Fax: +49 221 49708 - 178
 Internet: <http://www.heinrichs.eu>, Email: <mailto:info@heinrichs.eu>

2.2 Product type

Magnetic-inductive flowmeter based on Faraday’s law of induction

2.3 Product name

EP



2.4 Issue date

13.02.2017

2.5 Version no.

File: EP_BA_15_en.doc

2.6 Designation/rating plate

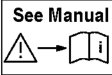
 <p>Heinrichs KOBOLD Group D-50739 Köln Robert-Perthel-Str. 9 www.heinrichs.eu</p> 	Type:	EP-H325B1H010	
	Ser. No.:	265843	
	TAG No.:	-	
	MF-Date:	2012/04	
	CONNECTION:	DN65 PN16 B1 EN 1092-1	
	WETTED PARTS:	Electrodes HC4 / Lining HG	
	Tm:	-20°C to 80°C	
	Tamb:	-20°C to 60°C	
	PS:	16 bar PT: 24 bar	
	Qmin =	880 l/h	Qmax = 17600 l/h
	Sensor Constant C:	2,26 m3/h/mV	
	Excitation frequ.:	6,25 Hz	
	Protect:	IP 67	
	PED /	1G	
Cable fittings:	M20 x 1,5		
			

The rating plate states the following information:

Logo	Manufacturer’s logo
Address	Manufacturer’s address (Internet address)
CE	CE Marking in accordance with the applied EC Directives
Type	Type designation
Code	Code of the model
Ser. No.	Serial number (for tracking reasons)
Tag No.	Operator’s measuring point number (if stated in the order)
T amb	Ambient temperature range
T m	Medium temperature range
C	Sensor constant
DN	Flange designation
PN	Pressure stage of flange
PS	Max. permissible process pressure
PED	<p>Information about the Pressure Equipment Directive</p> <ul style="list-style-type: none"> - For devices with a process connection =< DN 25: <ul style="list-style-type: none"> o There is no CE Marking in accordance with Section. 3 para. 3 of the PED. Under PED (Pressure Equipment Directive) the reason for exception in accordance with Section 3 para. 3 of the PDE is stated. The device is rated as SEP (Sound Engineering Practice). - For devices with a process connection > DN 25: <ul style="list-style-type: none"> o CE Marking with the number of the indicated institution that certified the manufacture of the device. o Fluid group (1G) in accordance with the PED; fluid group 1 comprises “dangerous fluids”.
Materials	Material of wetted parts such as pipe lining, material of electrodes and seal
MF-Date	Year of manufacture
Degrees of protection	Degrees of protection in accordance with DIN EN 60529:2000

3 Applications

The electromagnetic flowmeter is used to measure or monitor the volume flow of fluids with and without solids concentration, slurries, pastes and other electrically conductive media while minimizing pressure drops. The conductivity of the medium must be at least $5 \mu\text{S}/\text{cm}$. Pressure, temperature, density and viscosity do not affect the volume measurements. Small quantities of solid particles and small gas pockets are also measured as part of the volume flow. A larger number of solid particles or gas pockets will result in failures.

4 Operational mode and system design

4.1 Operational mode

In 1832 Faraday suggested utilizing the principle of electrodynamic induction for measuring flow velocities. His experiments in the Thames, though unsuccessful due to superimposed polarization effects, are nonetheless regarded as the first in the field of magnetic-inductive flow measurement. According to Faraday's law of electromagnetic induction, an electrical field E is produced in a conductive liquid moving through a magnetic field B at a velocity v in accordance with the vector product $E = [v \times B]$.

A fluid with a flow velocity v and a flow rate Q flowing through a tube (1) with an insulating lining (2) produces a measuring-circuit voltage U_m at the two electrodes (4) at right angles to the direction of flow and the magnetic field B generated by the field coils (3). The strength of this measuring-circuit voltage is proportional to the mean flow velocity and therefore the volume flow rate.

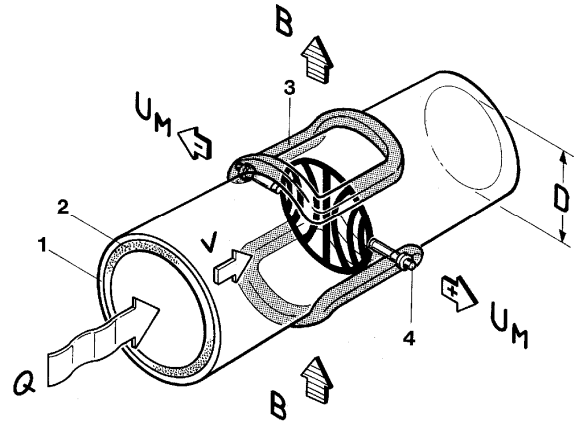

4.2 System design

The electromagnetic EP-*** flowmeter consists of a sensor, which picks up an induced measuring signal from the medium flowing through the pipe, and a transmitter which transforms this signal into standardized output signals (4-20 mA or pulses). The sensor is installed in the pipe while the transmitter is mounted directly on the sensor (integral mount) or separately at an external location (remote mount), depending on the device version.

4.2.1 Integral mount transmitter

This type of configuration ensures easy and trouble-free installation.

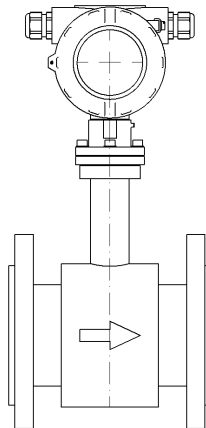

4.2.2 Remote mount transmitter

This type of configuration is recommended for confined spaces or if the temperature of the fluid is high. The connection between the sensor and the transmitter is established with a cable with separately shielded circuits for field coils and electrodes.

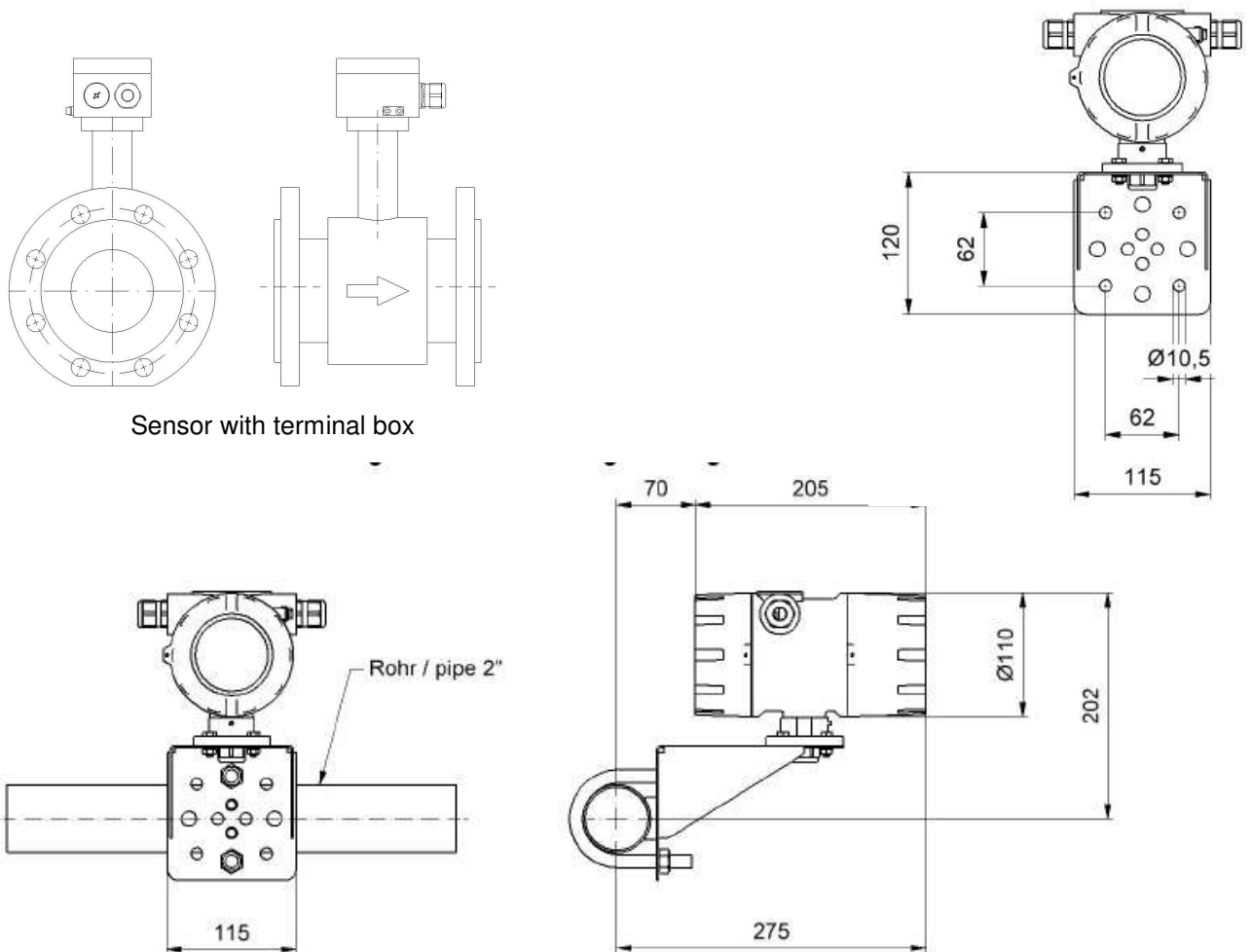

Sensor with terminal box

Transmitter with wall / pipe mounting bracket

5 Performance characteristics

5.1 Measuring accuracy

5.1.1 Measured error

+/- [0.3 % of actual value + 0.0001 * (Q at 10 m/s)]

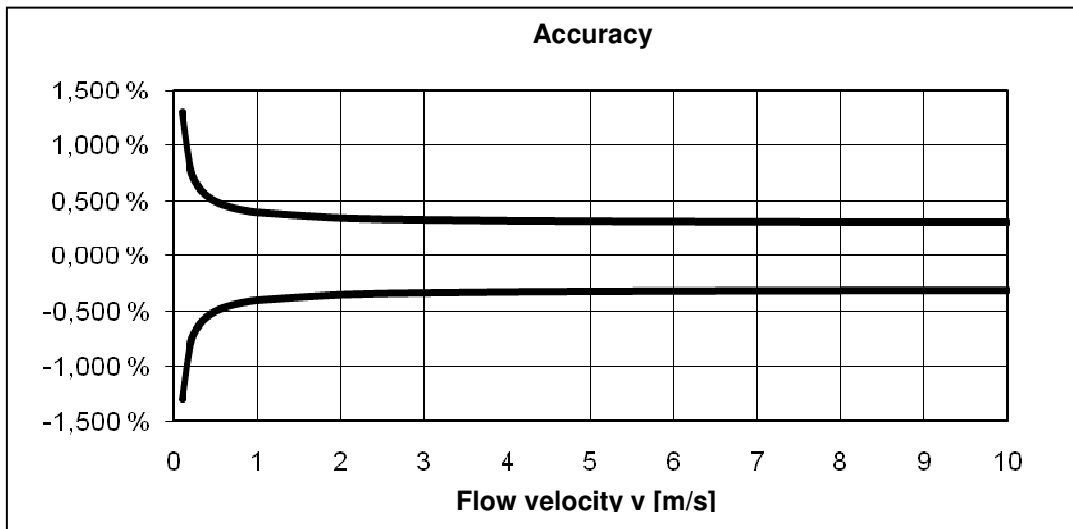

5.1.2 Repeatability

+/- [0.15 % of actual value + 0.00005 * (Q at 10 m/s)]

5.1.3 Reference conditions

In accordance with DIN EN 29104

- Fluid temperature 22 °C ± 4 K
- Ambient temperature 22 °C ± 2 K
- Inlet section of ≥ 10 x DN and outlet section of ≥ 5 x DN

5.2 Fluid conductivity

≥ 5 μS/cm (≥ 20 μS/cm for demineralized water)

5.3 Influence of ambient temperature

See Operating Instructions of the corresponding transmitter

5.4 Influence of fluid temperature

None

5.5 Materials

5.5.1 Wetted parts

Parts	Standard	Others
Lining	Hard rubber	PTFE (PFA), E-CTFE, soft rubber, Rilsan, Wagunit
Measuring and grounding electrodes	St.st. 1.4571, Hastelloy C4	Tantalum, Platinum
Grounding disk	St.st. 1.4571	Hastelloy C4, Tantalum
Tri-Clamp® connection	St.st. 1.4404 (316L)	<i>(on request)</i>
Hygienic Conn. DIN 11851	St.st. 1.4404 (316L)	<i>(on request)</i>

5.5.2 Non-wetted parts

Parts	Standard	Others
Flow tube	Stainless steel 1.4571	
Housing DN 10 – 300	Varnished steel	Stainless steel (standard with connections DIN11851, Tri-Clamp®)
Flange	Varnished steel	
Terminal box for remote mount transmitter	Aluminum pressure casting, varnished	

6 Installation/conditions for use

6.1 Receipt of goods and transport

6.1.1 Receipt of goods

- Check the packaging and contents for damage.
- Inspect the supplied goods to ensure complete delivery and compare the consignment with your order specifications.

6.1.2 Transport

- If possible the devices should be forwarded in the packaging in which they were delivered.
- Do not remove any protection disks or caps from the process connections. This is particularly important in the case of sensors with a PTFE flow tube lining. The protection caps should only be removed immediately before installation of the device in the pipe.
- Never lift the devices by the mounted transmitter housing or terminal box for transport. When transporting heavy devices, use slings. Place these around both process connections. Do not use chains as these can damage the surface coating and the housing.
- When transporting devices without lugs, and when looping the slings around the flow tube, the center of gravity of the entire device can be higher than both attachment points of the slings. When transporting the device ensure that it does not rotate or slip accidentally. This could cause injury.
- Sensors with a nominal width of more than DN 150 should not be lifted by the sheet metal of the shell with a forklift truck. This could dent the sheet metal of the shell and damage the internal solenoid coils. There is also the risk that the device could roll off the forks.

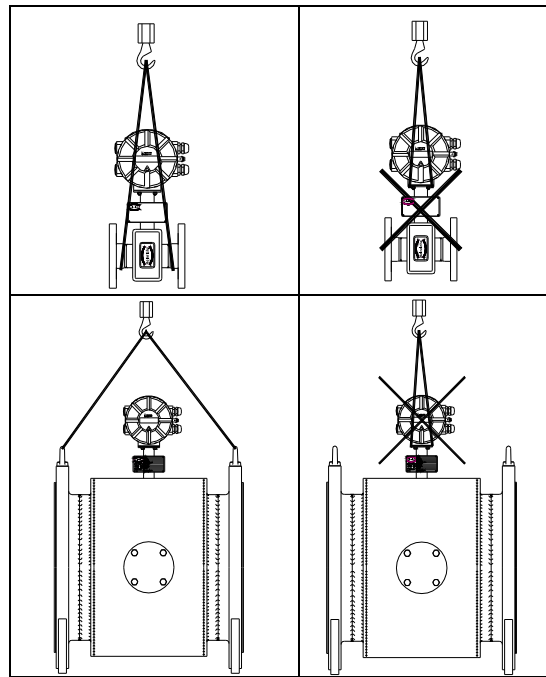

6.2 Installation conditions

The installation location in the pipe must be selected so that the sensor is always fully filled with the fluid and cannot run empty. This can best be guaranteed if it is installed in an ascending pipe or drain.

The measuring principle is generally independent of the flow profile of the fluid provided no standing vortices reach into the area where the measurement takes place, such as downstream from elbows or half-open sliding valves upstream from the sensor. In these cases measures must be taken to normalize the flow profile. Practical experience has shown that in most cases a straight **inlet section of $\geq 5 \times \text{DN}$** and an **outlet section of $\geq 2 \times \text{DN}$** of the nominal diameter of the sensor is sufficient. The occurrence of strong electromagnetic fields in the vicinity of the installed sensor must be avoided.

For the implementation of forward and backward flow measurements, both sides of the sensor must be provided with a straight pipe section with the nominal diameter of the sensor and a length of 5 DN of the nominal diameter of the sensor. It is advisable to install actuators, such as regulating or shut-off devices, downstream from the sensor. The forward flow direction is marked on the sensor with an arrow. When mounting sensors, always observe the specified screw torques.

The electrical system can be taken into operation when the sensor and the cables have been installed and connected. In order to prevent measuring errors caused by gas pockets in the fluid and damage lining of the sensor caused by negative pressure, the following points must be observed.

6.2.1 Long pipe-systems

As pressure surges may occur in long pipes systems, the regulating and shut-off devices must be installed downstream from the sensor. When mounted in vertical pipes - in particular in flow tubes with PTFE lining and in case of higher operating temperatures - the regulating and shut-off devices must be installed upstream from the sensor. (Danger of vacuum might be involved!)

6.2.2 Pumps

Do not mount the sensor on the suction side of a pump (Danger of vacuum!)

6.2.3 Bypass

In order to easily dismount, empty and clean the sensor, a bypass pipe may be installed. The bypass with a blind flange permits the fluid pipe to be cleaned without having to dismount the flowmeter. This is recommended for highly soiling fluids.

6.2.4 Flow tube lining

If the flow tube is lined with PTFE, the flowmeter must be installed with special care. The tube lining is bordered at the flanges (seal). This must not be damaged or removed as it prevents the fluid from penetrating between flange and flow tube destroying the electrode insulation.

6.3 Installation

Screws, bolts, nuts and seals are not supplied by Heinrichs Messtechnik GmbH and must therefore be provided by the operator. Install the sensor between the pipes. Please observe the required torques stated Section 6.3.5. The installation of additional grounding rings is described in Section 6.3.4.3.2. Use for the flanges only seals in accordance with DIN 2690. Mounted seals must not reach into the pipe cross section.

Caution!



Do not use conductive sealing compounds such as graphite. This could result in a conductive layer on the inside of the flow tube that short-circuits the measuring signal.

6.3.1 Installation in pipes with larger nominal sizes

The flowmeter can also be installed in pipes with larger nominal sizes by using pipe tapers (e.g. flange transition pieces in accordance with DIN EN 545). However, the resulting pressure loss must be taken into consideration. In order to avoid flow interruptions in the flow tube, a reducing angle $\leq 8^\circ$ for the tapers should be adhered to.

6.3.2 Horizontal and vertical installation

The flowmeter can be installed wherever required, whereby the intended x-y electrode axis should run almost horizontal. A vertical Electrode axis should be avoided as otherwise the accuracy could be affected by the gas pockets or the solid particles in the fluid.

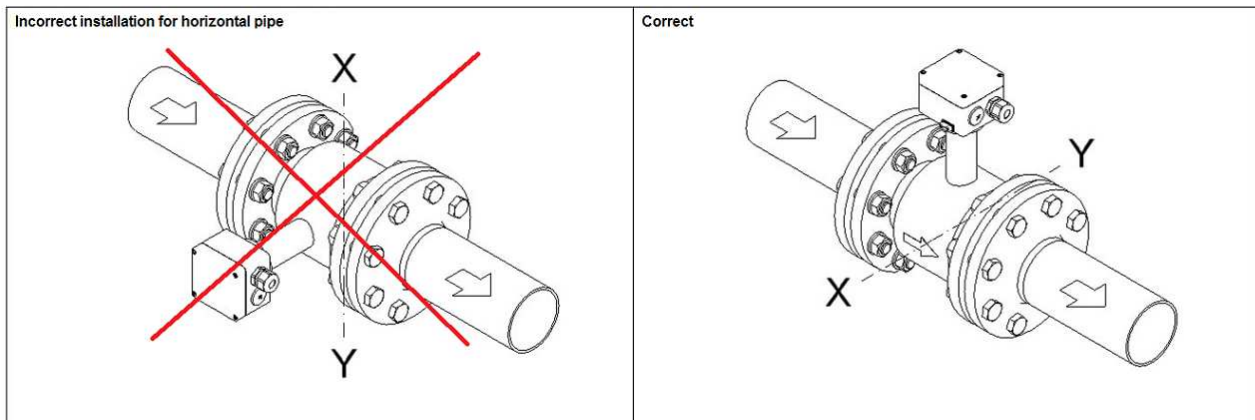

6.3.3 Installation examples

In order to avoid measuring errors caused by gas pockets and lining damage caused by negative pressure, the following points must be observed:

Highest point in pipe system.
Air bubbles will accumulate in the tube. Incorrect measurement!

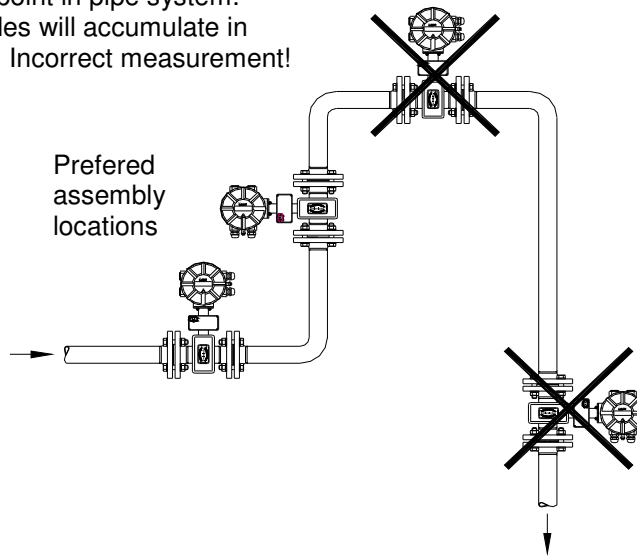

Horizontal lining

Installation in a slightly ascending pipe.

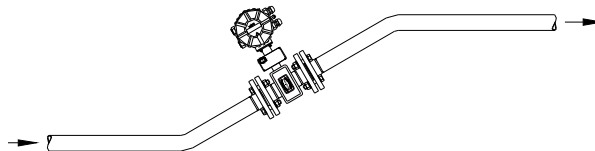

Free inlet or outlet section

Preferably install the device in a drain. The empty pipe detection circuit in the transmitter is an additional safety feature for recognizing empty or partially filled pipes.

Caution! There is the danger of accumulations of solids in the drain. It is advisable to arrange for a cleaning aperture in the pipe.

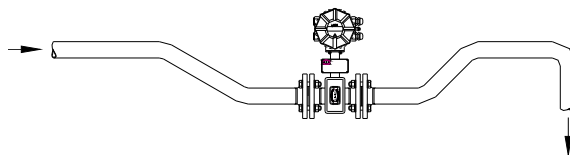

Fall pipe over five meters long

In case of fall pipes that are more than five meters long, arrange for a syphon or a venting valve in order to avoid a negative pressure in the pipe and damage to the lining. In addition, this measure prevents the flow from stopping so that air pockets can be avoided.

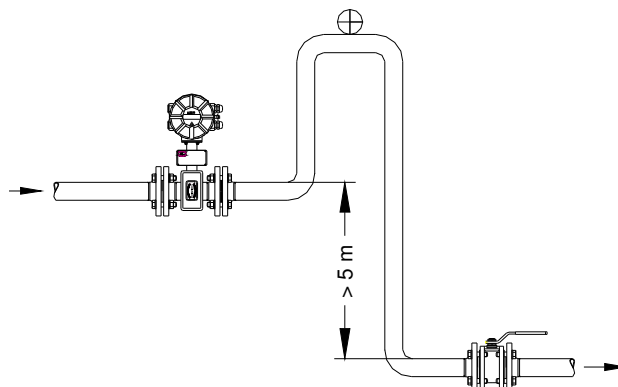

Long pipes

Always install regulating and shut-off devices **downstream** from the sensor (Danger of vacuum!).

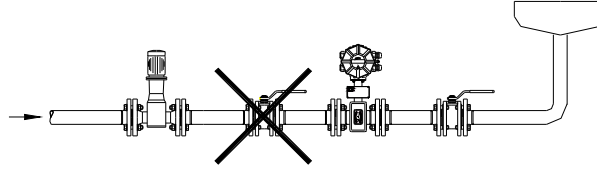

Installation of pumps

Do not install flowmeters on the suction side of pumps in order to avoid a negative pressure and damage to the tube lining.

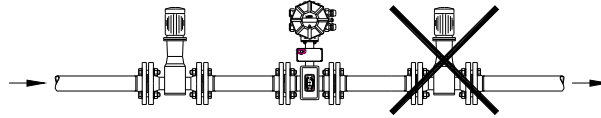

If necessary, arrange for pulsation dampeners when using piston, diaphragm or hose pumps.

Please consider space requirements with respect to a potential deinstallation of the device.

6.3.4 Grounding

For safety reasons as well as to ensure faultless operation of the electromagnetic flowmeter, the sensor must be grounded. In accordance with VDE 0100 Part 410 and VDE 0100 Part 540 the grounding connections must be at protective conductor potential. For metrological reasons, the potential should be identical to the potential of the fluid. The grounding cable should not transmit any interference voltage. For this reason do not ground other electrical devices with this cable at the same time.

The measuring signal tapped at the electrodes is only a few millivolts. Correct grounding of the electromagnetic flowmeter is therefore an important prerequisite for exact measurement. The transmitter requires a reference potential to evaluate the measured voltage on the electrodes. In the simplest case the non-insulated metal pipe and/or the connecting flange may be used as a reference potential.

In case of pipes with an electrically insulating lining or pipes made of plastic, the reference potential is picked up from a grounding disk or grounding electrode. These establish the necessary conductive connection to the fluid and are made of a chemical-resistant material. The material used should be identical to that of the measuring electrodes

6.3.4.1 Grounding electrodes

The device can be optionally equipped with grounding electrodes. With plastic pipes this version is the easiest grounding method. As the surface of the grounding electrode is relatively small, the use of grounding disks on both sides is preferable in systems in which high equalizing currents can be expected to occur along the pipe.

6.3.4.2 Grounding rings

The outside diameter of the grounding ring should be at least equal to the diameter of the flange seal or be dimensioned in such a way that the grounding ring is positioned inside the flange bolts and is centered by these. The terminal lugs routed to the outside must be connected to the FE terminal in the junction box of the sensor. During installation ensure that the internal seals do not protrude over the grounding disk!

The grounding cables are not included in the scope of supply and must be provided by the plant operator. The grounding rings can be ordered as accessories. Refer to Section 7.6 for dimensions.

6.3.4.3 Grounding examples for the EP flowmeter

6.3.4.3.1 Uninsulated metal pipe

- F Sensor flange
- RF Pipe flanges
- D Sealing
- E Grounding rings
- PE Ground
- PA Equipotential bonding
- FE Functional ground

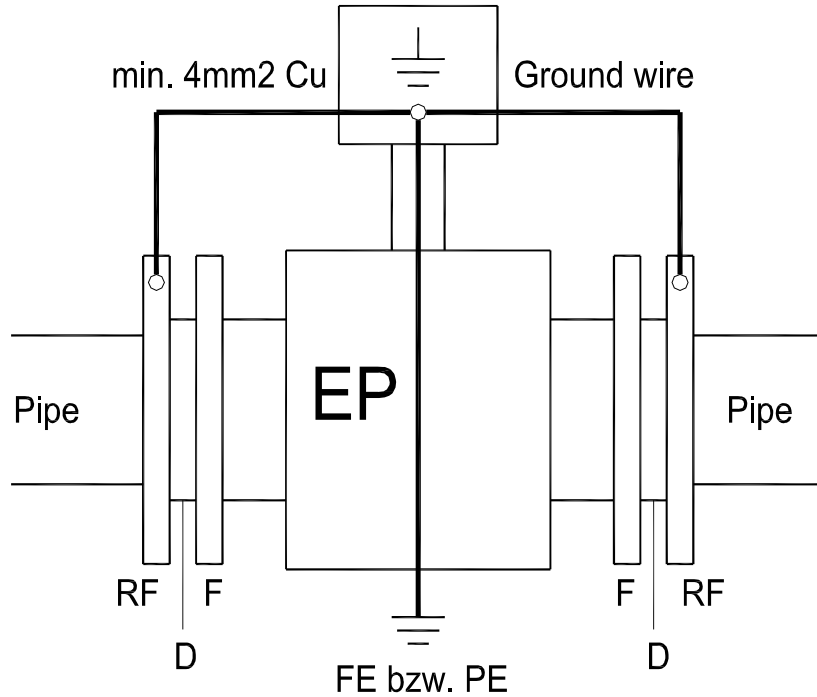

6.3.4.3.2 Plastic pipes or lined metal pipes

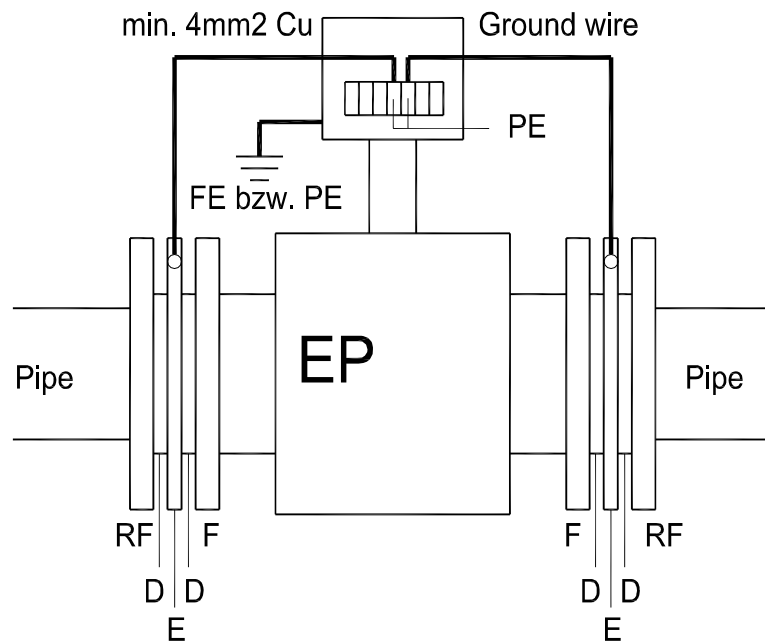

6.3.5 Torques for screws and bolts

Electromagnetic flowmeters must be installed in the pipe system with special care due to the fact that the flow pipe lining is made of plastic or vulcanized materials such as hard rubber. PTFE for example is malleable under pressure. If the flange screws are tightened too much, the sealing surface will deform. If the seals are supposed to function properly, the correct torque is highly important.

Tighten the screws crosswise so that the process connections are tight. When tightening the screws for the first time approx. 50 percent of the required torque should be reached, and for the second time the torque should be 80 percent. The required torque should reach 100 percent when the screws are tightened for the third time. For higher torques it is advisable to use protectors.

The following tables states the maximum torques:

Nominal size [mm]	DIN Pressure rating [bar]	Screws	Maximum torques [Nm]			
			Pipe lining			
			Hard rubber	PTFE	PFA	
10(LW 6,8,10mm)	PN 16		-	-	15	
15	PN 40	4 x M12	-	15		
25	PN 40	4 x M12	-	25		
32-40	PN 40	4 x M16	-	45		
50	PN 40	4 x M16	-	65		
65	PN 16	4 x M16	32	85		
65	PN 40	8 x M16	32	45		
80	PN 16	8 x M16	40	55		
80	PN 40	8 x M16	40	55		
100	PN 16	8 x M16	43	55		
100	PN 40	8 x M20	59	80		
125	PN 16	8 x M16	56	75		
125	PN 40	8 x M24	83	110		
150	PN 16	8 x M20	74	100		
150	PN 40	8 x M24	104	135		
200	PN 10	8 x M20	106	140		
200	PN 16	12 x M20	70	95		
200	PN 25	12 x M24	104	140		
250	PN 10	12 x M20	82	110		
250	PN 16	12 x M24	98	130		
250	PN 25	12 x M27	150	200		
300	PN 10	12 x M20	94	125		
300	PN 16	12 x M24	134	180		
300	PN 25	16 x M27	153	205		

Nominal size [inch]	ANSI Pressure rating [lbs]	Screws	Maximum torques [Nm]			
			Pipe lining			
			Hard rubber	PTFE	PFA	
½"(cw 6,8,10mm)	Class 150		-	-	6	
½"	Class 150	4 x ½"	-	6		
½"	Class 300	4 x ½"	-	6		
1"	Class 150	4 x ½"	-	11		
1"	Class 300	4 x 5/8"	-	15		
1 ½"	Class 150	4 x ½"	-	25		
1 ½"	Class 300	4 x ¾"	-	35		
2"	Class 150	4 x 5/8"	-	45		
2"	Class 300	8 x 5/8"	-	25		
3"	Class 150	4 x 5/8"	60	80		
3"	Class 300	8 x ¾"	38	50		
4"	Class 150	8 x 5/8"	42	55		
4"	Class 300	8 x ¾"	58	65		
6"	Class 150	8 x ¾"	79	105		
6"	Class 300	12 x ¾"	70	75		
8"	Class 150	8 x ¾"	107	145		
10"	Class 150	12 x 7/8"	101	135		
12"	Class 150	12 x 7/8"	133	180		
14"	Class 150	12 x 1"	135	260		

6.3.6 Remote mount transmitter

The transmitter must be installed separately from the sensor if:

- the installation area is difficult to access,
- space is restricted,
- the fluid and ambient temperatures are high,
- there is strong vibration.

Caution!

- The cable between transmitter and sensor must be shielded. The outer cable shield must be connected at both ends with special EMC cable glands (e.g. type Hummel HSK-M-EMV).
- For the remote mount version, the minimum permissible conductivity of the fluid is determined by the distance between the sensor and the transmitter. To ensure accuracy, the maximum cable length of 200 m should not be exceeded.
- The electrode cable must be fixed. If the conductivity of the fluid is low, cable movements may change the capacity considerably and thus disturb the measuring signals.
- Do not lay the cables close to electrical machines and switching elements.
- Do not connect or disconnect the field coil cable before the primary power of the flowmeter has been disconnected.
-

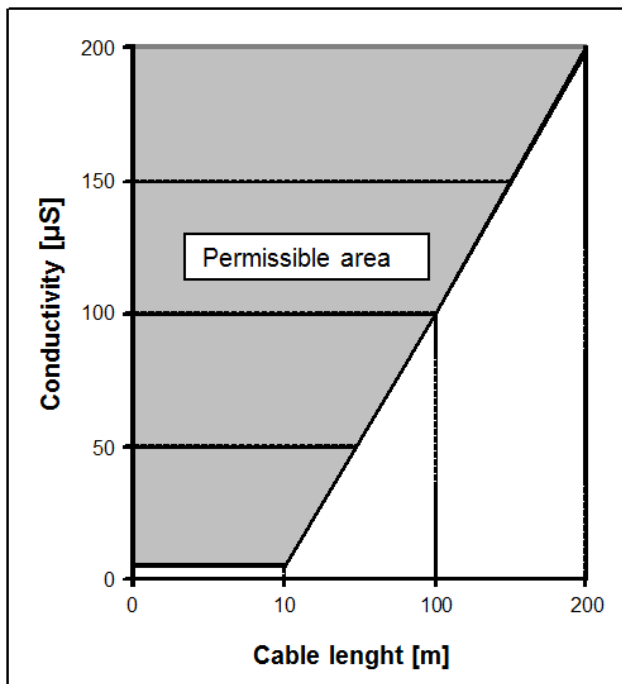

6.4 Wiring

Caution!



Installation and wiring may only be performed when the auxiliary power is switched off. Non-compliance can result in electric shock and irreparable damage to electronic parts. When fitting versions with a remote mount transmitter:

- Only sensors and transmitters with the same serial number may be interconnected. If this is not the case, errors in measurement can occur.
- Ensure that the stripped and twisted inner cable shield ends in the terminal box up to the terminal are as short as possible. If necessary these must be covered with an insulating hose to prevent short circuits.
- The outer cable shield must be connected to EMC cable screw connectors at both ends.

6.4.1 Integral mount transmitter

On the integral mount transmitter the connections to the sensor are internally wired. The terminal assignment is described in the operating manual of the transmitter.

6.4.2 Remote mount transmitter type UMF2 (B)

On the transmitter type UMF2 (B) the sensor cables are provided as a cable tail, which is mounted on the transmitter at the works. The cable length is normally specified in the order.

With cable length larger than 10m the UMF2 (B) will be equipped with an own terminal box.

Regard the terminal assignment 6.4.2.1.

The shielding of the cable must also be connected to the sensor housing on the sensor side with a special metal EMC cable gland.

6.4.2.1 Terminal assignment

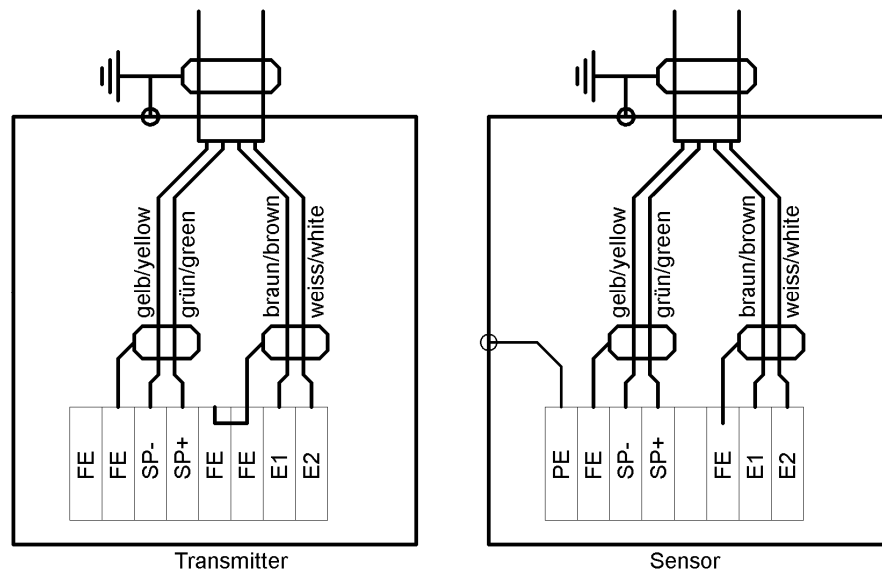

6.4.2.2 Connecting the cable shield in the cable gland

For optimum interference suppression connect the sensor cable shield in the special metal cable glands.

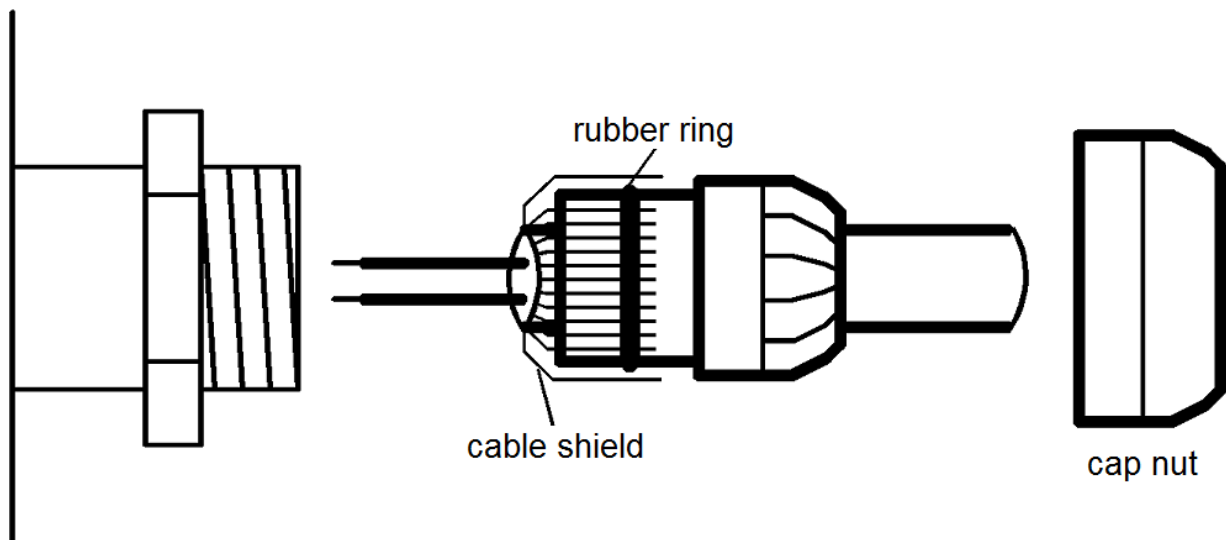

6.5 Nominal size and ranges

Volume flow depends on the flow velocity and the nominal size of the flowmeter. The following flow rate nomogram shows the flow range which can be measured by a device with a specific nominal size and also nominal size suitable for a specific flow rate. The electromagnetic flowmeter has been designed in such a way that it operates within the range of the flow velocities occurring in practical applications. The flow velocities have an upper range value of between 0.5 m/s and 10 m/s.

The nominal size DN of the sensor must be selected, if possible, in such a way that the flow velocity does not drop below the upper range value of 0.5 m/s. In case of fluids with solid particles, the flow velocity should range between 3 m/s and 5 m/s in order to prevent sedimentation in the sensor.

The flow nomogram shows the volume flow in m³/h and the flow velocity in m/s in relation to the nominal size DN of the sensor. The y-axis shows the flow values in m³/h. The nominal size DN of the sensor has been selected as parameters for the plotted straight lines. The upper range measuring value m³/h is taken as a basis for determining the sought nominal size DN. This value is given on the y-axis. The value for the flow velocity in m/s is shown on the x-axis. The straight line of the nominal size DN is found at the intersection of the two variables.

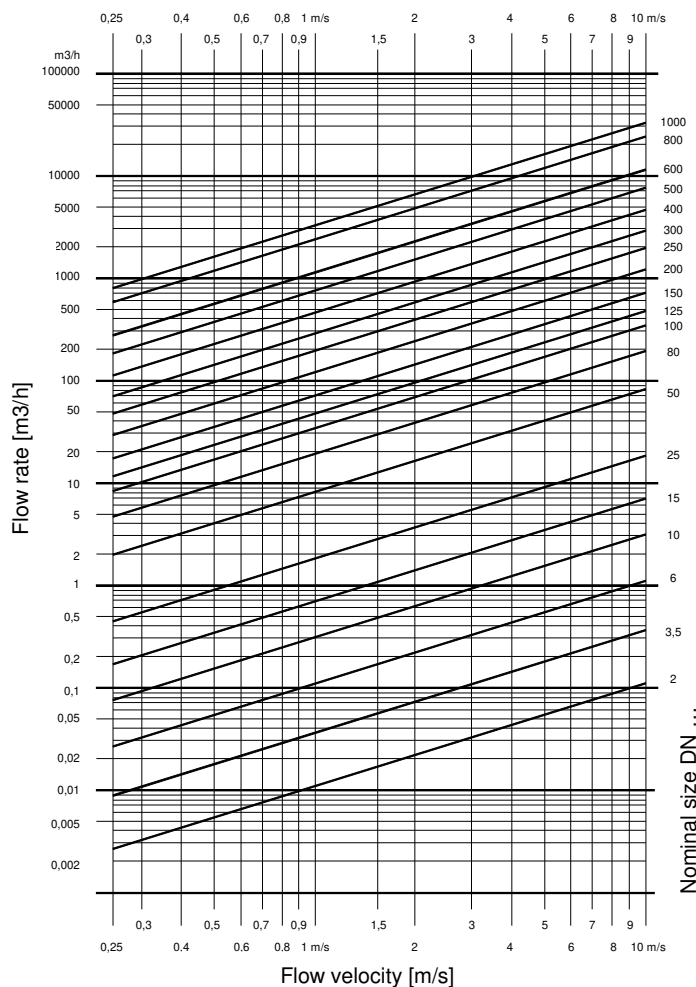

DN / ANSI	Liter / sek.		m ³ /h	
	Qmin	Qmax	Qmin	Qmax
6 / 1/2"	0,01	0,28	0,05	1
8 / 1/2"	0,03	0,50	0,09	1,8
10 / 1/2"	0,04	0,78	0,14	2,8
15 / 1/2"	0,09	1,75	0,32	6,3
20 / 3/4"	0,11	2,25	0,41	8,1
25 / 1"	0,24	4,89	0,88	17,6
32 / 1 1/4"	0,40	8,03	1,45	28,9
40 / 1 1/2"	0,54	10,75	1,94	38,7
50 / 2"	0,87	17,33	3,12	62,4
65 / 2 1/2"	1,56	31,11	5,61	112
80 / 3"	2,27	45,28	8,17	163
100 / 4"	4	80	14,42	288
125 / 5"	6	127	22,8	456
150 / 6"	9	186	33,96	671
200 / 8"	17	330	59,99	1188
250 / 10"	27	527	95,57	1897
300 / 12"	37	745	134,98	2682
350 / 14"	46	908	164,39	3269
400 / 16"	60	1195	216,13	4301
450 / 18"	76	1514	273,7	5449
500 / 20"	95	1886	340,82	6789
600 / 24"	137	2734	493,78	9842
700 / 28"	188	3750	675	13500
800 / 32"	247	4939	889	17780
900 / 36"	312	6249	1124	22497
1000 / 40"	233	7760	838	27936
1100 / 44"	470	9400	1692	33840
1200 / 48"	561	11216	2018	40376

6.6 Ambient conditions

6.6.1 Ambient temperature range

For fluid temperatures > 60 °C

As the sensors are an element of the pipe, these are normally thermally isolated when installed to save energy and prevent accidental physical contact. Due to the process temperature heat is introduced through the support for securing the integral mount transmitter or the terminal box. For this reason the thermal insulation of the sensor should not extend over more than half of the support. It is essential to prevent inclusion of the installed transmitter or the terminal box in the thermal insulation. The maximum permissible fluid temperature range is stated on the rating plate of the respective version.



6.6.1.1 Integral mount transmitter: maximum ambient temperature depending on the fluid temperature

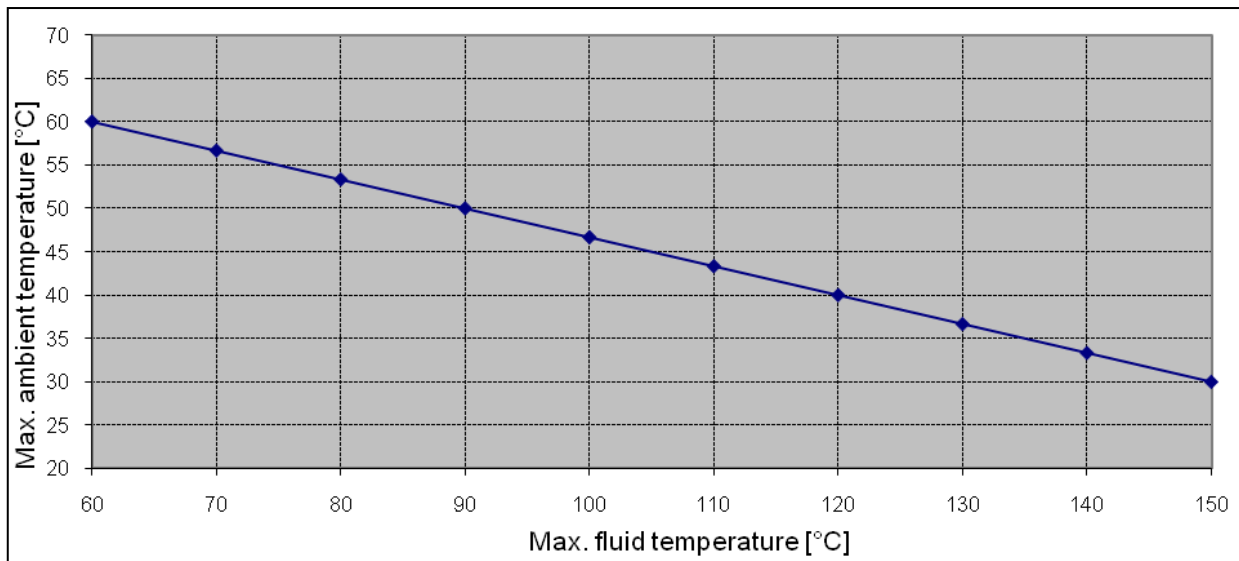

6.6.1.2 Remote mount transmitter: sensor maximum ambient temperature depending on the fluid temperature

It must be ensured that the temperature close to the terminal box does not exceed 70 °C.

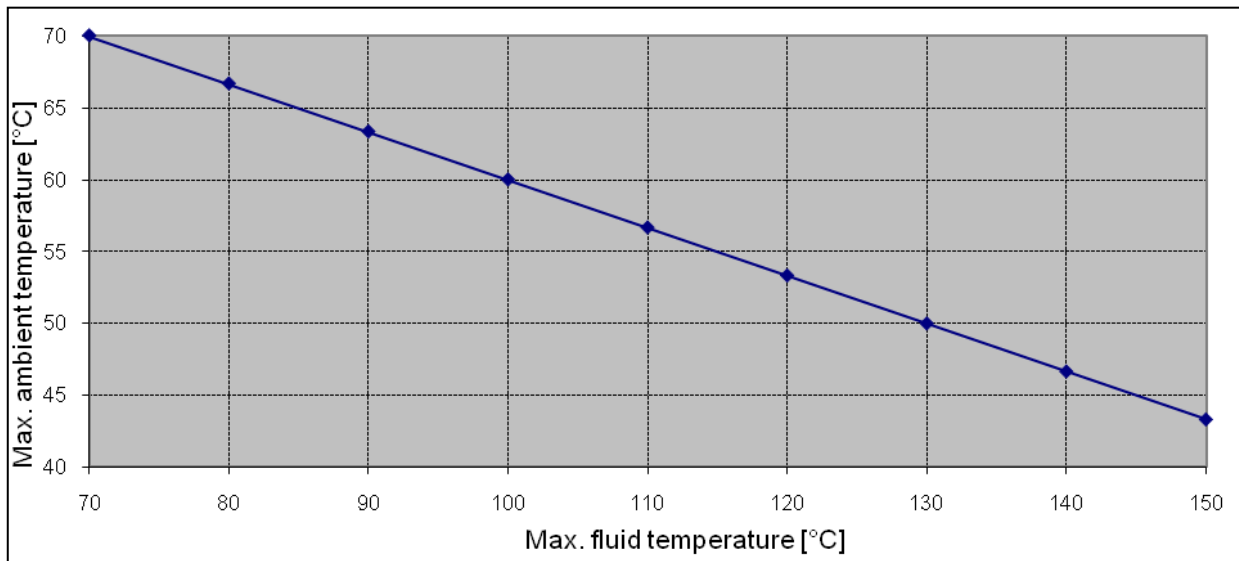

6.6.1.3 Remote mount transmitter: maximum ambient temperature depending on the fluid temperature

The permissible ambient temperature of the sensor is -20 °C to +60 °C.

6.6.2 Storage temperature range

The storage temperature range is identical to the ambient temperature range.

6.6.3 Climatic category

In accordance with DIN EN 60654-1; not weather-protected **Class D1** locations exposed directly to open-air climate.

6.6.4 Ingress protection

The sensor meets the requirements of the protection class **IP 67**. The following must be observed to ensure compliance with protection class IP67 when the device has been installed or serviced:

- The housing seals must be clean and undamaged when placed in the sealing groove. If necessary the seals must be cleaned or replaced.
- Tighten the cover screws of the terminal box and tighten the screw cap of the transmitter (integral mount version).
- The cables used for connection must comply with the specified outer diameter for the cable glands used.
- Tighten the cable glands firmly.
- Loop the cable in front of the cable gland. Any moisture running along the cable can then drip off and not penetrate the device. Always install the device so that the cable gland does not face upwards.
- Any unused cable glands must be closed with a plug which is suitable for the respective protection class.

The sensors are also available in an **IP 68** version. The maximum permissible immersion depth in water is **5 m**. In this case the transmitter is installed separately from the sensor. The cable at the sensor is connected through the manufacturer and the junction box is resin filled (standard version not Ex). A special cable is used as a connection cable.

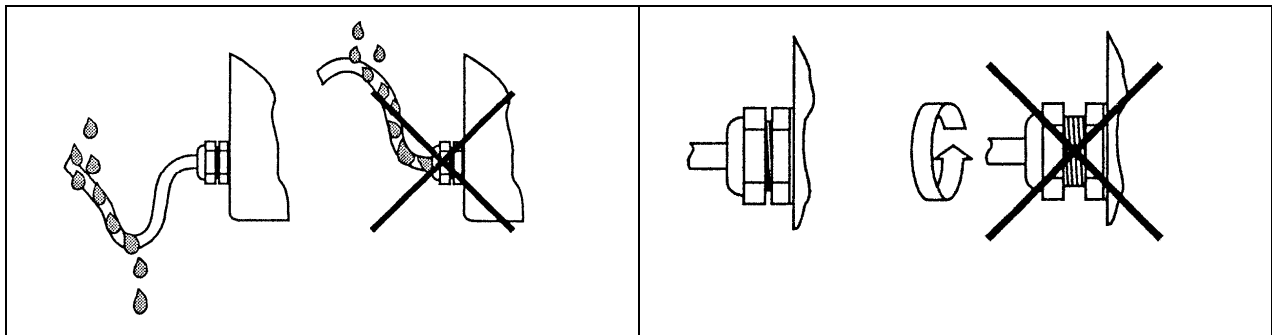

6.6.5 Shock resistance/vibration resistance

The flowmeter should be protected from extreme shocks and vibrations, which could cause damage. Maximum permissible shock/vibration: 15 m/s² (10 to 150 Hz).

6.7 Process pressure

The maximum permissible process pressure PS is stated on the rating plate and depends on the fluid temperature.

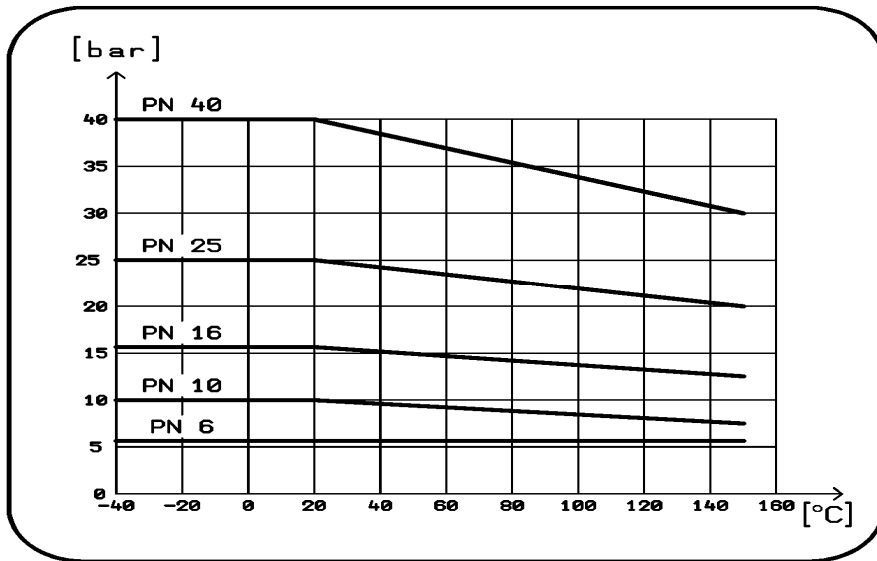

6.8 Fluid temperature

The maximum permissible fluid temperature of the device depends on the version and the lining material of the flow tube and is stated on the rating plate. The German Industrial Safety Act stipulates that very cold or hot components of working equipment must be provided with guards which prevent physical contact of workers with the respective parts. For this reason and also to save energy, in practical applications at temperatures of > 60 °C, all pipes and installed measuring instruments are normally thermally insulated.

Refer to Section 6.6.1 for information on the relation between the fluid temperature and the ambient temperature limits.

The temperature ranges for use of the device are listed below for the lining materials

Lining material	Fluid temperature ranges
Hard rubber	0 °C to 80 °C
Soft rubber	0 °C to 80 °C
Wagunit	0 °C to 80 °C
PTFE	- 20 °C to 150 °C
E-CTFE	- 20 °C to 130 °C
PFA	-20 °C bis 140 °C
Rilsan	0 °C to 100 °C

7 Dimensions and weights

7.1 Dimension drawing of EP-***: DN 10 to DN 1200, flange version

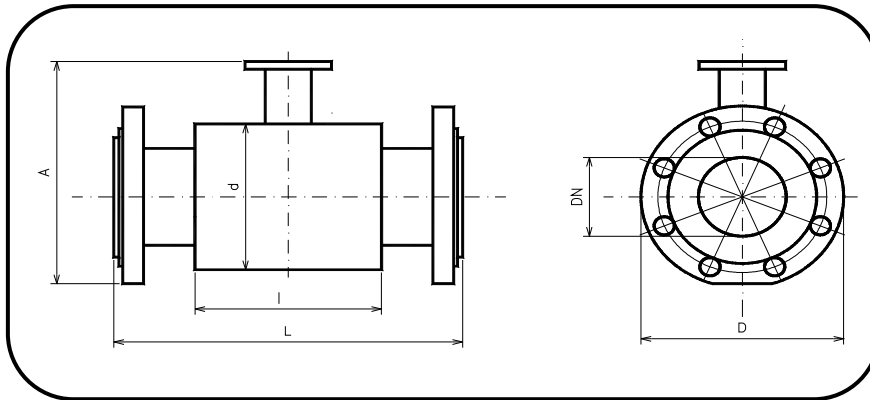

The flanges correspond to DIN EN 1092-1 or ANSI B16.5 150 lbs

Standard Pressure rating	DN	ASME	D / D-ANSI	d	A*	L	l	Weight [kg]
PN 40	6mm/DN10	1/2"	90 / 88.90	77	164	230	100	3
	8mm/DN10	1/2"	90 / 88.90	77	164	230	100	3
	10mm/DN10	1/2"	90 / 88.90	77	164	230	100	3
	15	1/2"	95	62	164	200	66	3
	20	3/4"	105	62	170	200	66	3
	25	1"	115	72	180	200	96	3
	32	1 1/4"	140	82	199	200	96	4
PN 16	40	1 1/2"	150	92	209	200	96	4
	50	2"	165	107	223	200	96	6
	65	2 1/2"	185	127	244	200	96	9
	80	3"	200	142	260	200	96	14
	100	4"	220	162	280	250	96	16
	125	5"	250	192	310	250	126	19
	150	6"	285	218	340	300	126	25
PN 10	200	8"	340	274	398	350	211	41
	250	10"	395	370	480	450	211	54
	300	12"	445	420	535	500	320	77
	350	14"	505	480	584	550	320	92
	400	16"	565	530	642	600	320	116
	450	18"	o.r.	o.r.	o.r.	o.r.	o.r.	o.r.
	500	20"	670	640	752	600	320	167
PN 6	600	24"	780	760	870	600	320	315
	700	28"	895	880	990	700	420	o.r.
	800	32"	1060	960	1100	800	420	427
	900	36"	1075	1040	1185	800	520	o.r.
	1000	40"	1230	1140	1290	800	520	500
	1100	44"	o.r.	o.r.	o.r.	o.r.	520	o.r.
	1200	48"	1405	1340	1510	1000	520	680

* Size A is the largest sensor size without integral mount transmitter or terminal box.

The sensor weights are approximate values.

An additional weight of 2.4 kg (5.3 lbs) must be taken into consideration for the transmitter.

o.r. = (on request)

7.2 Dimensions of flangeless version

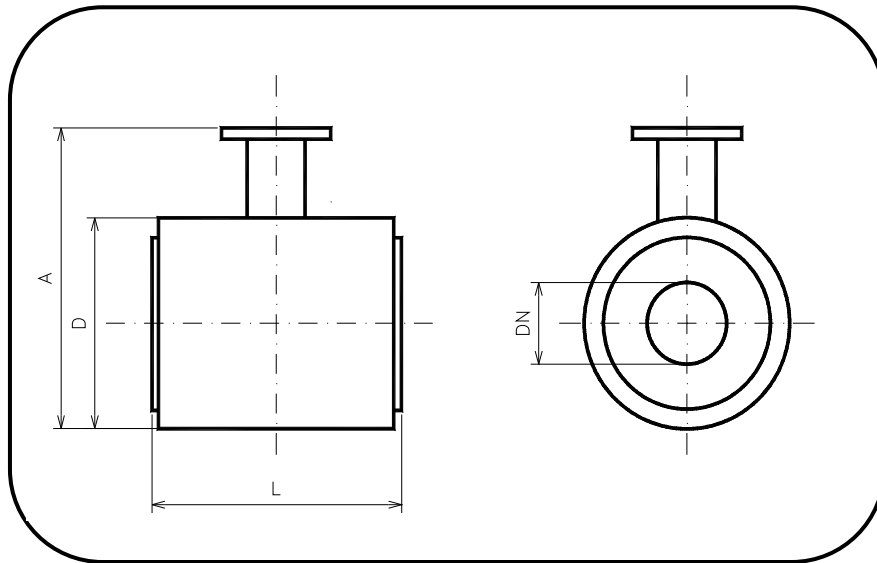

	DN	D	A*	L	Weight [kg]
PN 40	6	77	145	100	1,5
	8	77	145	100	1,5
	10	77	145	100	1,5
	20	62	145	74	1,5
	25	72	158	104	2
	32	82	168	104	2
PN 16	40	92	179	104	2
	50	107	192	104	3
	65	127	212	104	3
	80	142	227	104	4
	100	162	247	104	4
	125	192	277	134	6
	150	218	303	134	8
200	274	359	219	10	

* Size A is the largest sensor size without integral mount transmitter or terminal box.
 The sensor weights are approximate values.
 An additional weight of 2.4 kg (5.3 lbs) must be taken into consideration for the transmitter.
 o.r. = (on request)

7.3 Dimensions of food connection DIN 11851, PN10

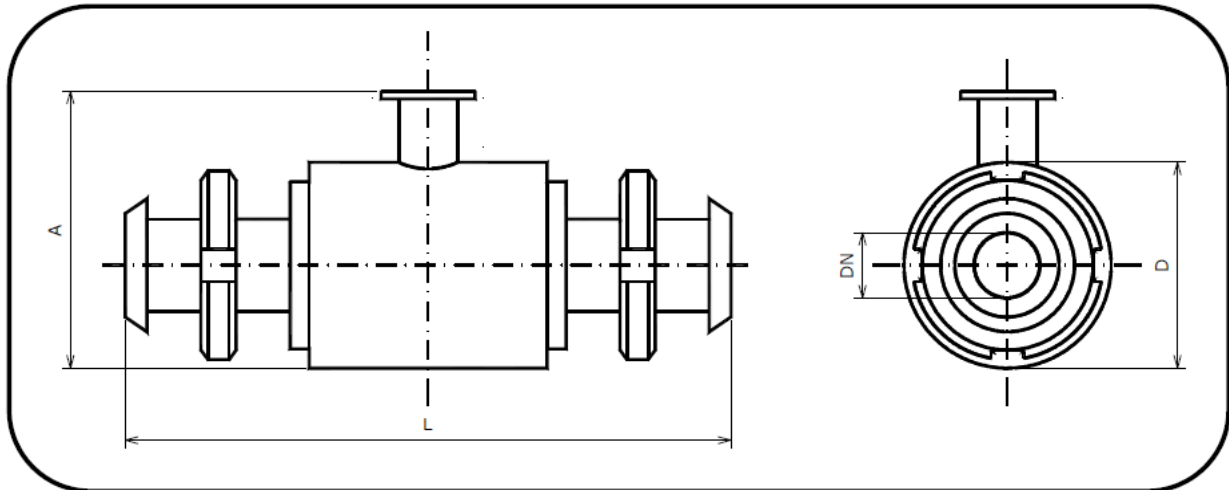

	DN	D	A	L
PN10	10	74	144	170
	15	74	144	170
	20	74	144	170
	25	74	144	225
	32	84	154	225
	40	94	164	225
	50	104	174	225
	65	129	199	280
	80	140	210	280
100	156	226	280	

7.4 Dimensions of connection Tri-Clamp®, PN10

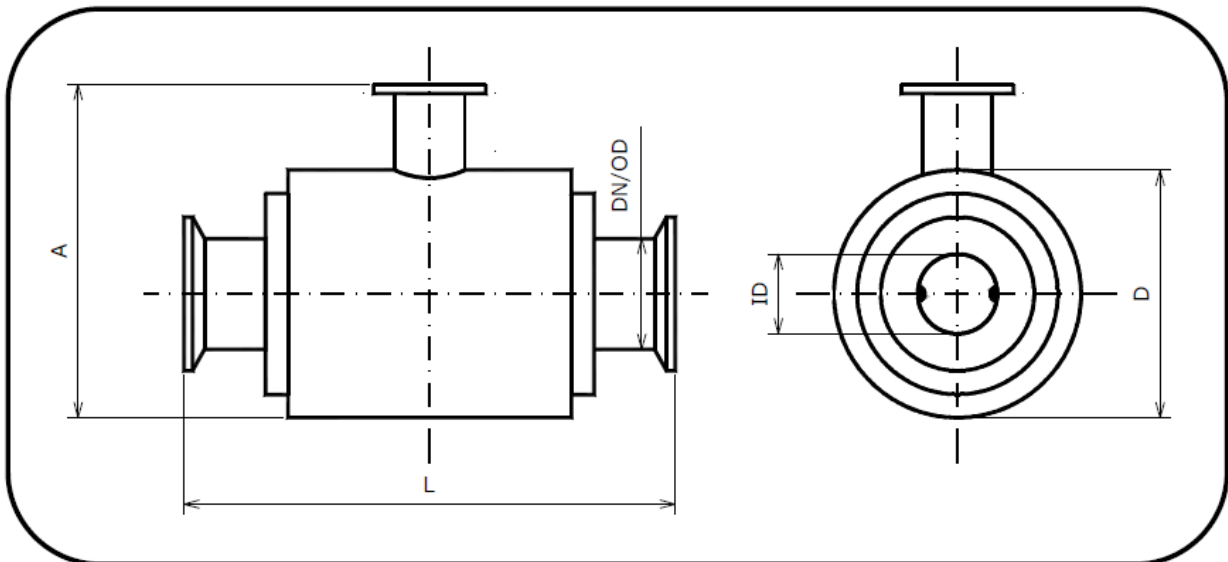

	DN/OD Inches (mm)	ID	D	A	L
PN10	½" (12.70)	9.40	74	144	145
	¾" (19.05)	15.75	74	144	145
	1" (25.40)	22.1	74	144	145
	1 ½" (38.10)	34.8	94	164	145
	2" (50.80)	47.5	104	174	145
	2 ½" (63.50)	60.2	129	199	200

7.5 Transmitter type UMF2 (B)

7.5.1 Integral mount transmitter

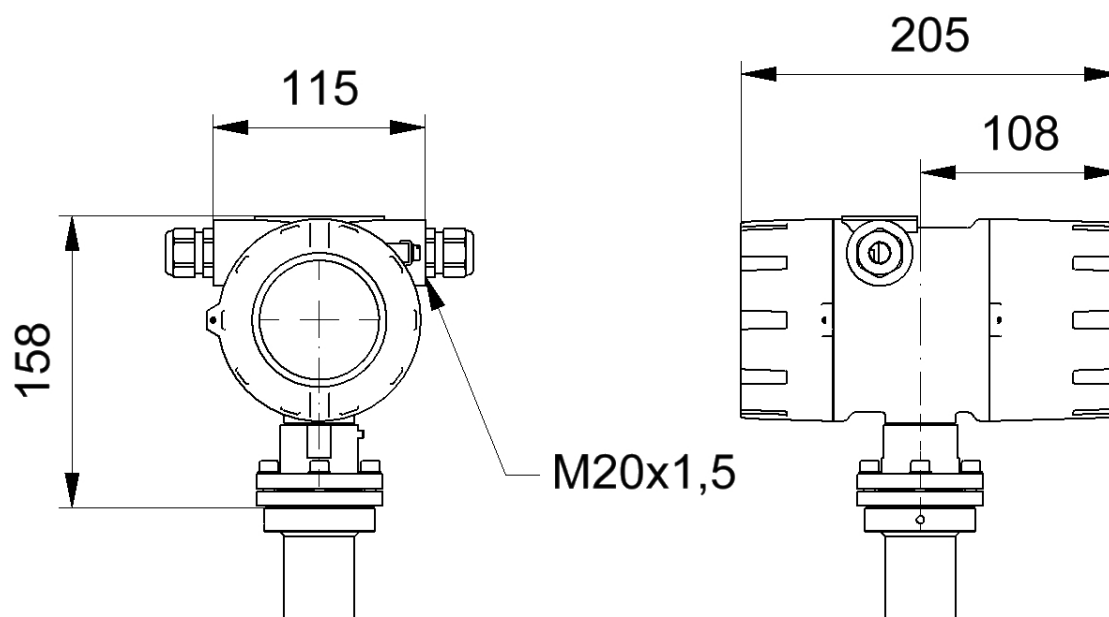

7.5.2 Sensor terminal box – remote mount transmitter

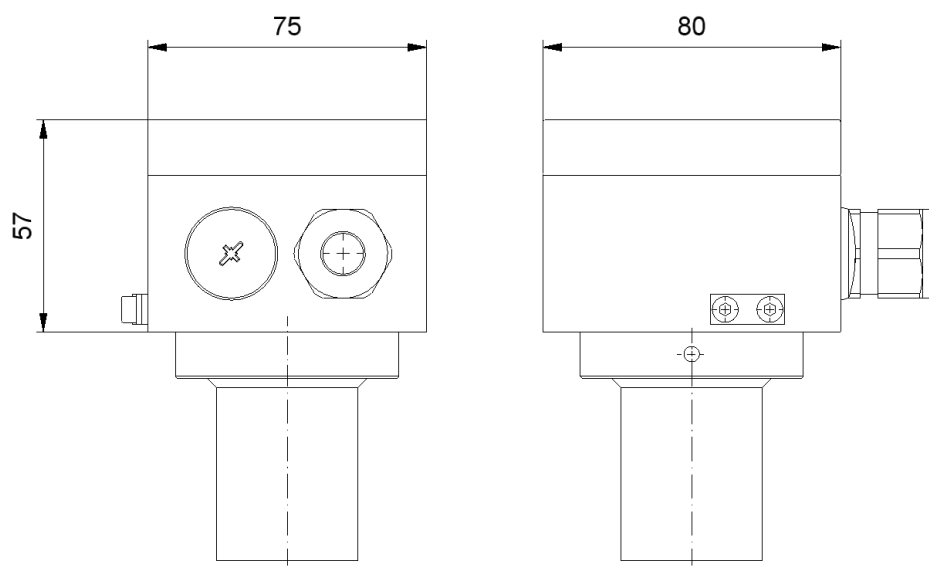

7.5.3 Wall mounting

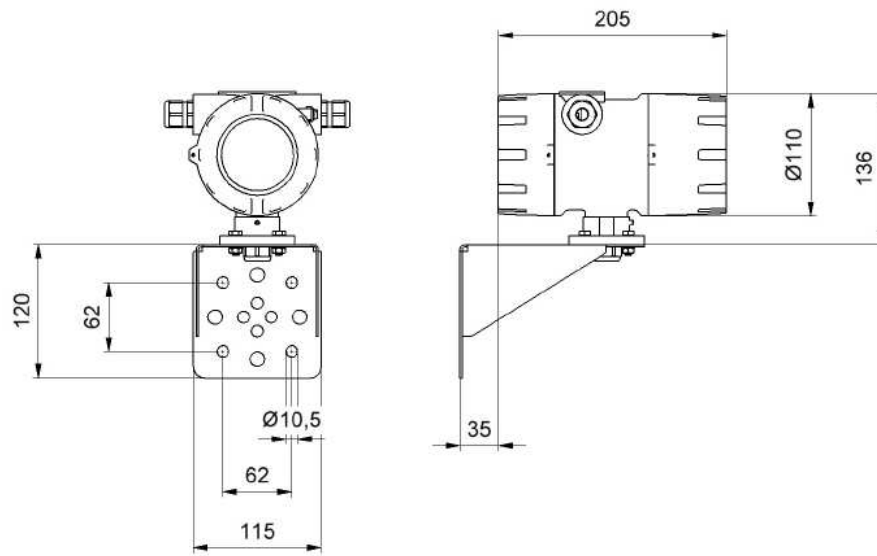

7.5.4 Pipe mounting – vertical position

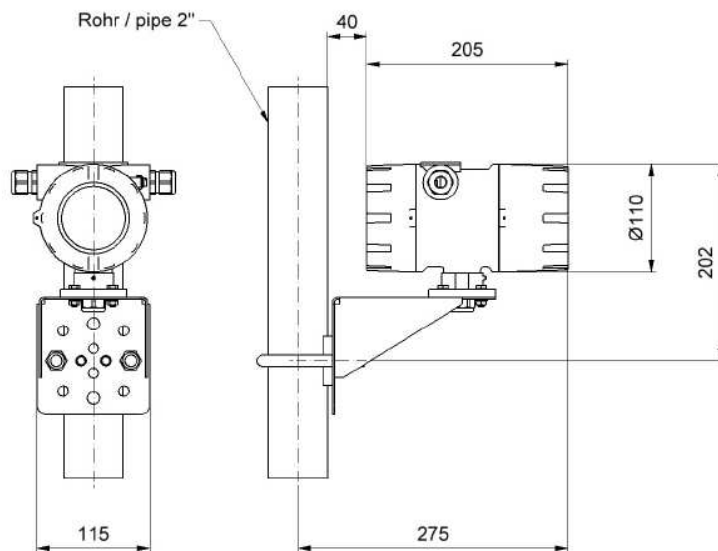

7.5.5 Pipe mounting – horizontal position

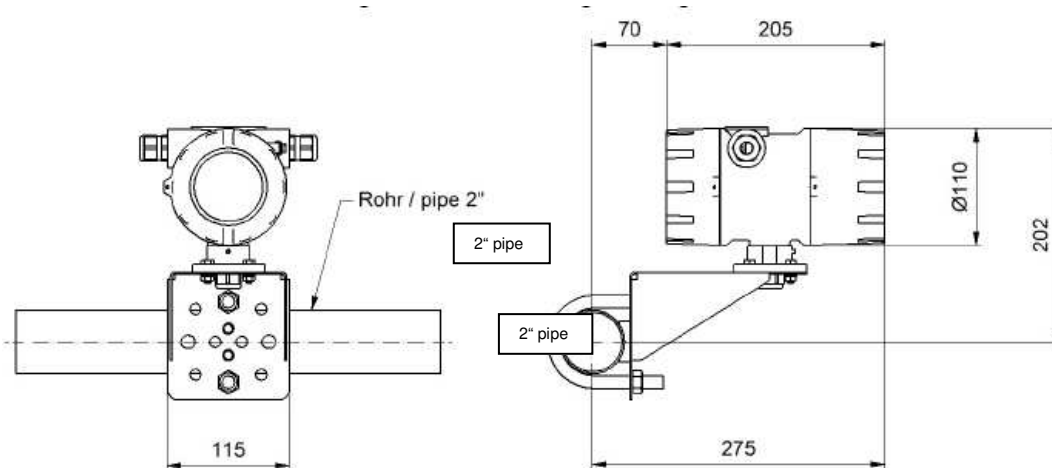

7.6 Dimension drawing: grounding rings

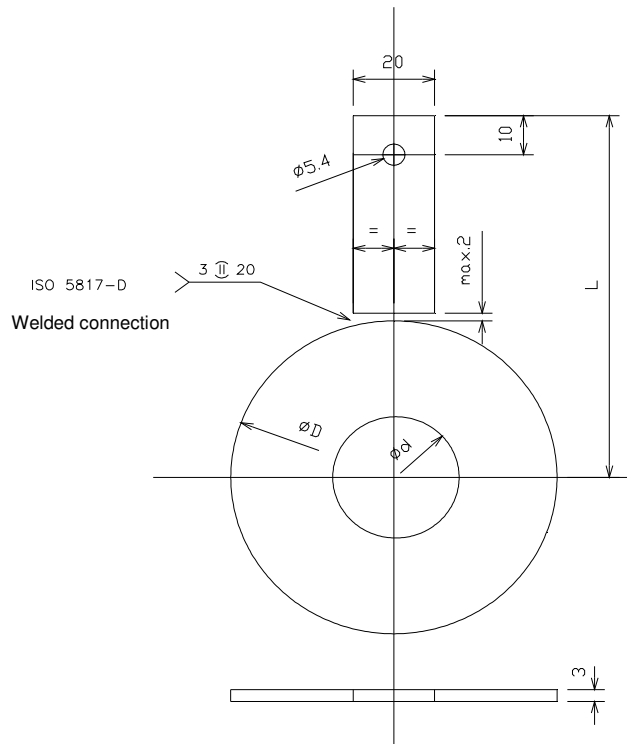

DN	PN	D [mm]	d [mm]	L [mm]
10	40	44	10	67.5
15	40	49	17	70
20	40	59	19	75
25	40	69	22	80
32	40	80	32	92.5
40	40	90	40	97.5
50	16	105	48	105
65	16	125	64	115
80	16	140	77	122.5
100	16	160	102	132.5
125	16	190	127	147.5
150	16	216	156	165
200	10	271	207	195
250	10	326	261	222.5
300	10	376	315	247.5

8 Maintenance

The device requires no maintenance if used according to its intended purpose. Cleaning might be necessary due to deposits and dirt on the electrodes or the flow tube.

9 Auxiliary power, electrical connection

See rating plate and the Operating Instructions of the corresponding transmitter.

10 CE-Marking

The measuring system complies with the legal requirements of the following EU Directives: Directive 2004/108/EC (*EMC Directive*), Directive 2006/95/EC (*Low Voltage Directive*) and Directive 97/23/EC (*Pressure Equipment Directive*). Heinrichs Messtechnik GmbH confirms compliance with the Directives by attaching the CE mark to the device.

11 Standards and directives, certificates and approvals

2014/35/EU (LVD) (Low Voltage Directive)

EN 61010-1:2011 - Safety requirements for electrical metering, control and laboratory devices

2014/30/EU (EMC)

EN 61000-6-2:2005

Immunity industrial environment

EN 61000-6-3:2007+A1:2011

Emitted interference residential environment

EN 55011:2009+A1:2010

Group 1, Class

2014/68/EU (PED) (Pressure Equipment Directive)

AD-2000 Guidelines

EN 60529:2010

Degrees of protection through housing (IP code)



Konformitätserklärung Declaration of Conformity

Nº. 16.4149.01

Hersteller: Heinrichs Messtechnik GmbH
Manufacturer: Robert-Perthel-Strasse 9
50739 Köln

Produktbeschreibung: **Magnetisch Induktives Durchflussmessgerät UMF2 (b)**
Product description: **für Verwendung mit der Sensorreihe EP und PIT***
Magnetic inductive flowmeter UMF2 (b) for use with the
sensor series EP and PIT*

Hiermit erklären wir, in alleiniger Verantwortung, dass das oben genannte Messsystem den Anforderungen der folgenden EU-Richtlinien, einschließlich allen bis heute veröffentlichten Änderungen bzw. Nachträgen entspricht:

We declare herewith, in sole responsibility, that the product described above is conform with the provisions of the following EU-directives, including all published changes and amendments as of today:

2014/30/EU (EMC)	EU-Richtlinie über die Elektromagnetische Verträglichkeit <i>EU-Directive relating to electromagnetic compatibility</i>
2014/35/EU (LVD)	EU-Richtlinie über die Bereitstellung elektrischer Betriebsmittel zur Verwendung innerhalb bestimmter Spannungsgrenzen auf dem Markt <i>EU-Directive relating to the making available on the market of electrical equipment designed for use within certain voltage limits</i>
2014/68/EU (PED)	EU-Richtlinie zur Harmonisierung der Rechtsvorschriften der Mitgliedstaaten über die Bereitstellung von Druckgeräten auf dem Markt <i>EU-Directive on the harmonisation of the laws of the Member States relating to the making available on the market of pressure equipment</i>

Anhang N ist ein integraler Bestandteil dieser Erklärung
Annex N is an integral part of this declaration

Köln, den 14.02.2017

Kontakt:
Contact:

Tel: +49 (221) 49708-0
Email: info@heinrichs.eu
Web: www.heinrichs.eu

Frank Schramm
(Geschäftsführung / General Management)

12 Decontamination certificate for device cleaning

Company name: Address:

Department: Name of contact person:

Phone:

Information pertaining to the enclosed flowmeter

Model EP-

was operated using the following fluid:

In as much as this fluid is water-hazardous / toxic / corrosive / combustible

we have done the following:

- Checked all cavities in the device to ensure that they are free of fluid residues*
- Washed and neutralized all cavities in the device*

*cross out all non-applicable items

We hereby warrant that no health or environmental hazard will arise from any fluid residues on or in the enclosed device.

Date:

Signature

Stamp