Magnetic-Inductive Flow Velocity Sensor

PIT

Installation and Operating Instructions

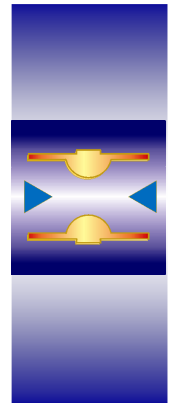

Table of contents

1	IDENTIFICATION	3
1.1	Manufacturer/supplier.....	3
1.2	Product type.....	3
1.3	Product name.....	3
1.4	Issue date	3
1.5	Version no.....	3
2	APPLICATIONS	3
3	OPERATIONAL MODE AND SYSTEM DESIGN.....	3
3.1	Operational mode.....	3
3.2	System design.....	3
3.2.1	Transmitter mounted on the sensor	4
3.2.2	Transmitter installed separately	4
3.2.3	PIT-520	4
3.2.4	PIT-580	4
3.2.5	PIT-571	4
3.2.6	PIT-573	4
4	CHARACTERISTIC VALUES.....	4
4.1	Measuring accuracy	4
4.2	Conductivity of the medium	4
4.3	Influence of ambient temperature	4
4.4	Influence of medium temperature	4
5	CONDITIONS OF USE	4
5.1	Installation conditions	4
5.1.1	Depth of immersion of the PIT-*** in the pipe.....	5
5.1.2	Dismounting/reinstalling the device under process pressure.....	5
5.1.3	Grounding	5
5.2	Use in hazardous areas.....	5
5.3	Ambient conditions	5
5.3.1	Ambient temperature ranges	5
5.3.2	Storage temperature	5
5.3.3	Climatic category.....	5
5.3.4	Degree of protection.....	5
5.3.5	Shock resistance/vibration resistance.....	5
5.4	Medium temperature and pressure.....	5
5.4.1	Transmitter is mounted on the sensor.....	5
5.4.2	Transmitter is mounted separately.....	5
6	DIMENSIONS/WEIGHT	6
6.1	PIT-5** dimension drawing for separate transmitter.....	6
6.2	PIT-5** dimension drawing with mounted transmitter in SG1 housing.....	7
7	AUXILIARY POWER/ELECTRICAL CONNECTION	8
8	CE MARKS	
9	STANDARDS AND DIRECTIVES, CERTIFICATES AND APPROVALS.....	8
10	SAFETY INFORMATION.....	8
10.1	Intended use	8
10.2	Installation, start-up and operating personnel	8
11	PACKAGING, STORAGE AND TRANSPORT	8
12	MAINTENANCE	8
13	RETURNING DEVICES FOR REPAIR AND SERVICE	8
14	OPTIONS	
14.1	Dismounting/reinstalling the device under process pressure.....	8
14.2	PIT with IP 68 degree of protection.....	9
14.2.1	Wiring diagram for IP 68 hazardous area version	9
14.2.2	Wiring diagram for IP 68 standard version	9
15	EC TYPE EXAMINATION CERTIFICATE	10
16	DECONTAMINATION CERTIFICATE FOR DEVICE CLEANING.....	12

Introduction

These Installation and Operating Instructions serve as a tool for the correct installation, operation and maintenance of the device. They are a supplement to the PIT Device Description. Read these manuals carefully before the device is installed and put into use. They do not include special versions or applications.

All devices were thoroughly checked for order compliance and operability before delivery. Upon receipt, please conduct a visual inspection of possible damage that may be identified as having occurred during shipment. If you discover any defect, please contact our head office in Cologne or the local sales office responsible for your area (see the telephone directory at the end of this manual or on our Web site). Apart from a description of the error, we will need the equipment type and serial number of the delivery.

Heinrichs Messtechnik shall not furnish guarantee for any repair work done without prior notice. Unless otherwise agreed on, the rejected parts must be made available to us in case a claim is made.

1 Identification

1.1 Manufacturer/supplier

Heinrichs Messtechnik GmbH
 Robert-Perthel-Str. 9 · D-50739 Köln
 Phone: +49 (221) 49708 - 0
 Fax: +49 (221) 49708 - 178
 Internet: <http://www.heinrichs.eu>
 E-mail: <mailto:info@heinrichs.eu>

1.2 Product type

Magnetic-inductive flow sensor based upon Faraday's law of induction

1.3 Product name

PIT-520, PIT-580, PIT-571 and PIT-573

1.4 Issue date

01/02/2017

1.5 Version no.

6.0

File: PIT_BA_06_en.doc

2 Applications

The magnetic-inductive PIT flow velocity sensor is used to measure or monitor the volume flow of liquids with and without solids concentration, slurries, pastes and other electrically conductive media while minimizing pressure drops. The conductivity of the medium must be at least 20 $\mu\text{S}/\text{cm}$.

Pressure, temperature, density and viscosity do not affect the volume measurements. Smaller portions of solid particles and small gas pockets are also measured as part of the volume flow. A larger number of solid particles or gas pockets will lead to failures. Special electrodes are available for media that tend to form greasy films or crusts.

3 Operational mode and system design

3.1 Operational mode

It was back in 1832 that Faraday suggested utilizing the principle of electrodynamic induction for measuring flow velocities. His experiments in the Thames, though unsuccessful due to superimposed polarization effects, are nonetheless regarded as the first ones in the field of magnetic-inductive flow measurement.

According to Faraday's law of electromagnetic induction, an electrical field E is produced in a conductive liquid moving through a magnetic field B at a velocity v in accordance with the vector product $E = [v \times B]$. A liquid at flow velocity v and a flow rate Q flows through a meter tube (4), producing a measuring-circuit voltage U_M at the two electrodes (E_1 and E_2) at right angles to the direction of flow and the magnetic field B generated by the field coils (3). The size of this measuring-circuit voltage is proportional to the mean flow velocity and thus the volume flow rate.

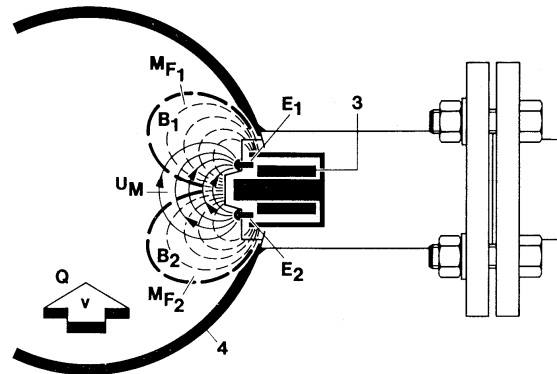

3.2 System design

The magnetic-inductive PIT-*** flow measurement system consists of a sensor, which picks up an induced measuring signal from the medium flowing through the pipe, and a transmitter, which transforms this signal in standardized output signals (4-20 mA or pulses).

The PIT-*** sensor can be operated with all transmitters for magnetic-inductive flowmeters manufactured by Heinrichs Messtechnik. The sensor is installed in the pipe while the transmitter is mounted directly on the sensor or separately on the outside, depending on the equipment design.

3.2.1 Transmitter mounted on the sensor

This type of construction ensures easy and trouble-free installation.

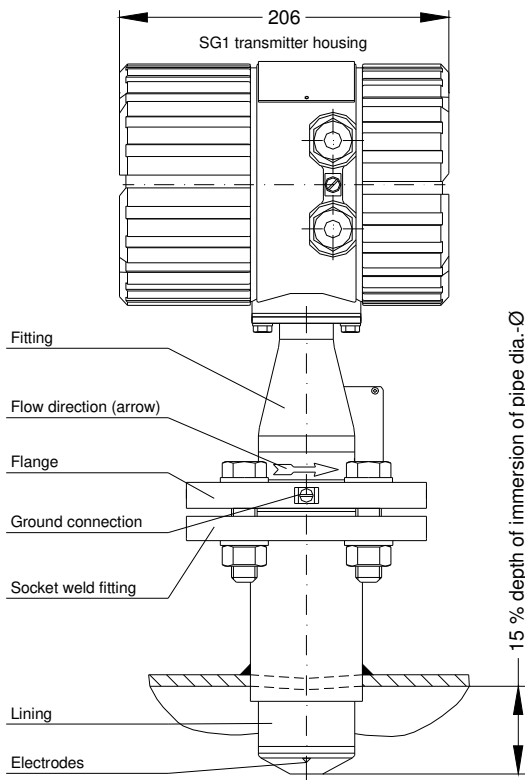

3.2.2 Transmitter installed separately

Heinrichs Messtechnik recommends this type of installation when there is little space or the medium temperatures are high. The sensor and the transmitter are connected by a field coil and an electrode cable. The electrode cable must be shielded and protected against disturbing interferences.

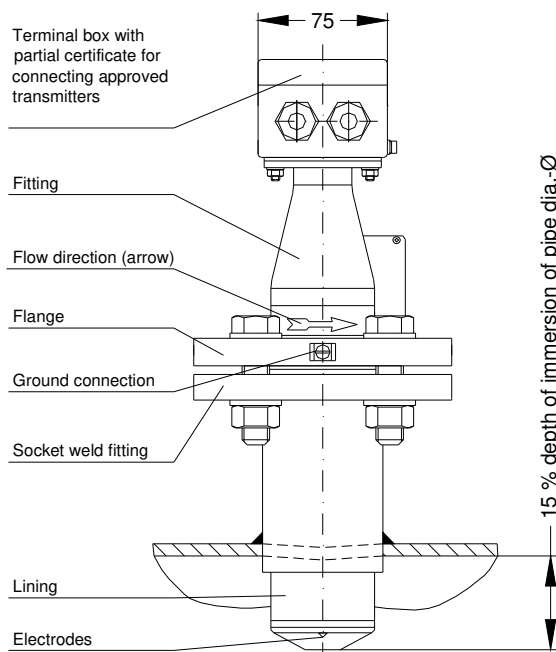

3.2.3 PIT-520

Socket of sensor housing and flange are made of stainless steel.

3.2.4 PIT-580

Socket of sensor housing and flange are made of Hastelloy.

3.2.5 PIT-571

Socket of sensor housing and flange are made of stainless steel. The wetted parts of the housing are PFA-coated.

3.2.6 PIT-573

Socket of sensor housing and flange are made of stainless steel. The wetted parts of the housing are PFDF-coated.

4 Characteristic values

4.1 Measuring accuracy

$\pm 1.5\%$ of measured value plus $\pm 0.5\%$ of URV

4.2 Conductivity of the medium

$\geq 20 \mu\text{S/cm}$

4.3 Influence of ambient temperature

See transmitter

4.4 Influence of medium temperature

None

5 Conditions of use

5.1 Installation conditions

Disturbing elements (e.g. shut-off and control devices) are to be arranged downstream from the sensor. If this is not possible, flow straighteners must be installed so that no vortices can reach into the pipe section of the sensor. The mounting location in the pipe system should be selected so that the sensor is continually filled with the medium. This requirement can be met by using drains and non-return valves.

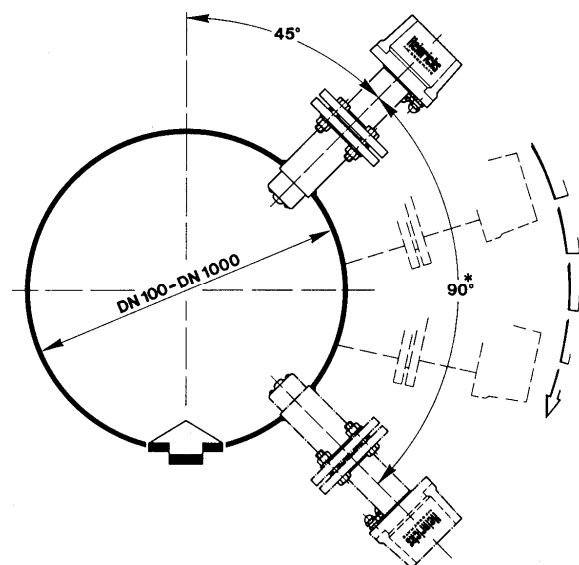

In order to stay within the indicated error limits, the installation must be performed according to EN 29104 "Measurement of Fluid Flow in Closed Conduits – Methods of Evaluating the Performance of Magnetic-Inductive Flowmeters." Based on this standard, the minimum straight run of pipe ahead of the inlet must be 10 pipe diameters (> **10 x DN**) and 5 pipe diameters following the outlet (> **5 x DN**) [DN = nominal diameter of pipe].

In order to prevent serious measuring errors when the pipe is partially filled or when there are gas pockets or sediment deposits, the mounting position described above should be chosen.

The limit values for the product and ambient temperature must be met at the mounting location. Corrosive atmospheres must be avoided. Please also take into account the space requirement for a possible removal of the device.

5.1.1 Depth of immersion of the PIT-* in the pipe**

In order to suppress the influence of the flow profile as much as possible, the depth of immersion of the measuring head in the pipe must be **15 % of the inside diameter of the pipe**. The socket weld fitting must not cover the top of the measuring head and must be shortened if necessary.

5.1.2 Dismounting/reinstalling the device under process pressure

For easily dismounting and reinstalling the device under process pressure, a version with a special mechanism is available. When using this mechanism, the measuring head must not be damaged by closing the valve.

For details, see the Additional Operating Instructions for Dismounting and Reinstalling the Device under Process Pressure (see also Section 14 "Options").

5.1.3 Grounding

For safety reasons and to ensure faultless operation of the magnetic-inductive flowmeter, grounding the flow sensor is important. In accordance with VDE 0100, Part 540, the ground connections must be at protective conductor potential. For the hazardous area version, they must be equipotentially bonded. For metrological reasons, the potential should be identical to the potential of the medium.

When using insulated and lined pipes or plastic pipes, the metrological grounding of the medium for PIT-520/580 is carried out via the wetted part of the measuring head.

All wetted parts of PIT-571 are coated with PFA (PIT-573 with PVDF). It is therefore not possible to ground the medium via the housing parts. In this case, a special version of PIT-571/PIT-573 equipped with a grounding electrode is necessary.

5.2 Use in hazardous areas

The PIT-520 and PIT-571 flowmeters can also be used in **Zone 1** hazardous areas. Only devices with a corresponding mark on their type plate may be operated in these areas. The special conditions with regard to the relationship between the thermal data and the medium temperature, ambient temperature and the temperature class in accordance with the EC Type Examination Certificate BVS 03 ATEX 150 X must be observed.

When installing and operating the device in hazardous areas, the applicable national rules must be followed.

5.3 Ambient conditions

5.3.1 Ambient temperature ranges

-40°C to +60°C

For the hazardous area version, take note of the maximum ambient temperatures depending on the temperature class as specified in the Type Examination Certificate.

5.3.2 Storage temperature

The storage temperatures are identical to the ambient temperature ranges.

5.3.3 Climatic category

- In accordance with IEC 654-1
- Not weather-protected **Class D locations** exposed directly to open-air climate

5.3.4 Degree of protection

- Standard version: IP 65
- Special version: IP 68
- Weather-protected and/or unheated locations, class C

5.3.5 Shock resistance/vibration resistance

The meter should be protected from extreme shocks and vibrations, which could cause damage.

5.4 Medium temperature and pressure

5.4.1 Transmitter is mounted on the sensor

Version	Medium temperature	Pressure
PIT-520/580 standard	-20°C to 80°C	16 bar
PIT-571 standard	-20°C to 80°C	40 bar
PIT-573 standard	-20°C to 80°C	40 bar

5.4.2 Transmitter is mounted separately

Version	Medium temperature	Pressure
PIT-520/580 standard	-40°C to 100°C	16 bar
PIT-571 standard	-40°C to 140°C	40 bar
PIT-573 standard	-20°C to 80°C	40 bar

6 Dimensions/weight

6.1 PIT-5** dimension drawing for separate transmitter

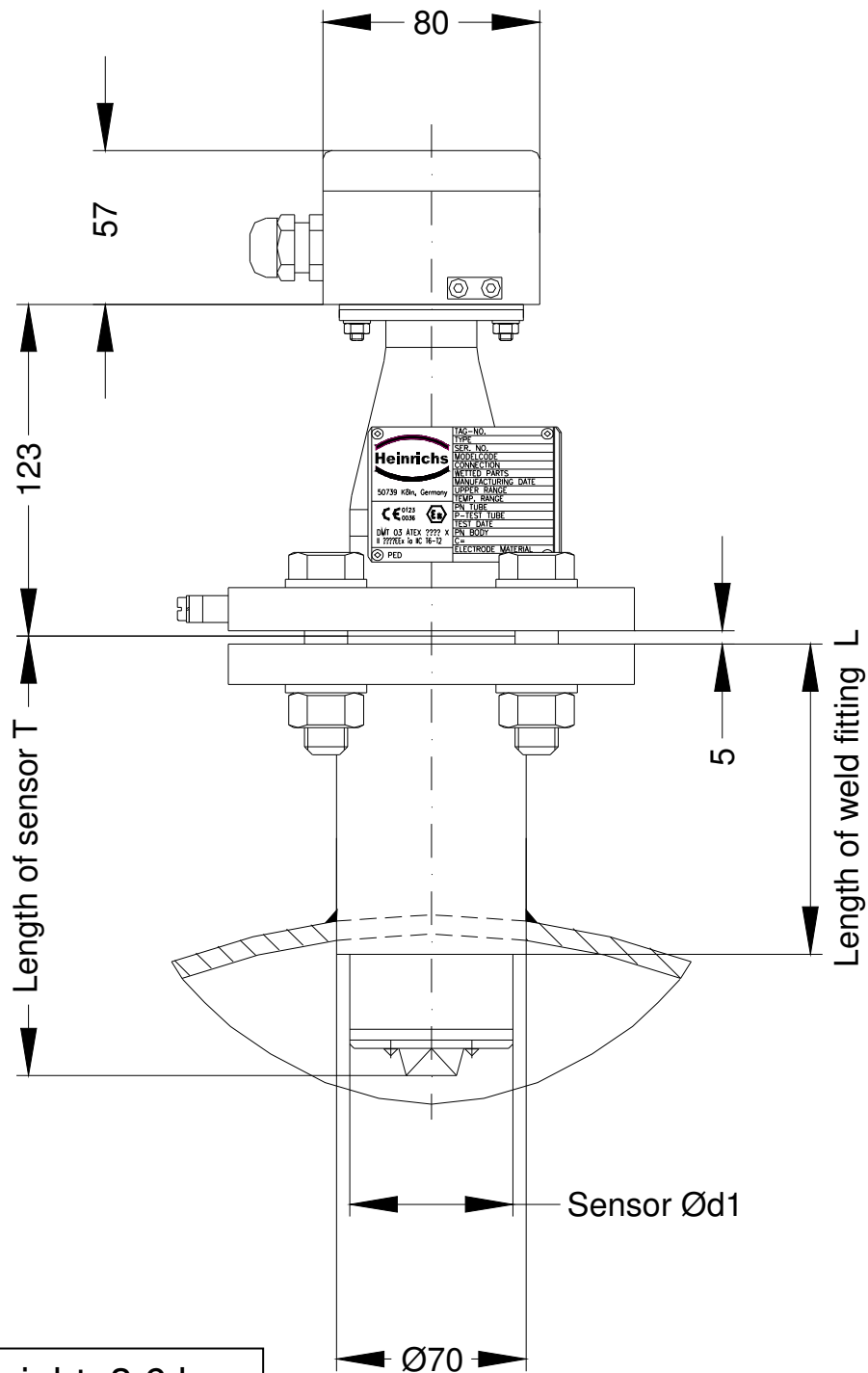

Weight: 3.6 kg

Version	DN	Sensor lining	Length of sensor T	Sensor-Ø	Length of weld fitting L
PIT-571	150 - 600	PFA	163	62	145
PIT-573	150 - 600	PVDF	163	62	145
PIT-520	150 - 600	1.4571	163	60,3	145
PIT-520	700 - 1200	1.4571	263	60,3	170
PIT-520	1400 - 2000	1.4571	363	60,3	170

6.2 PIT-5** dimension drawing with mounted transmitter in SG1 housing

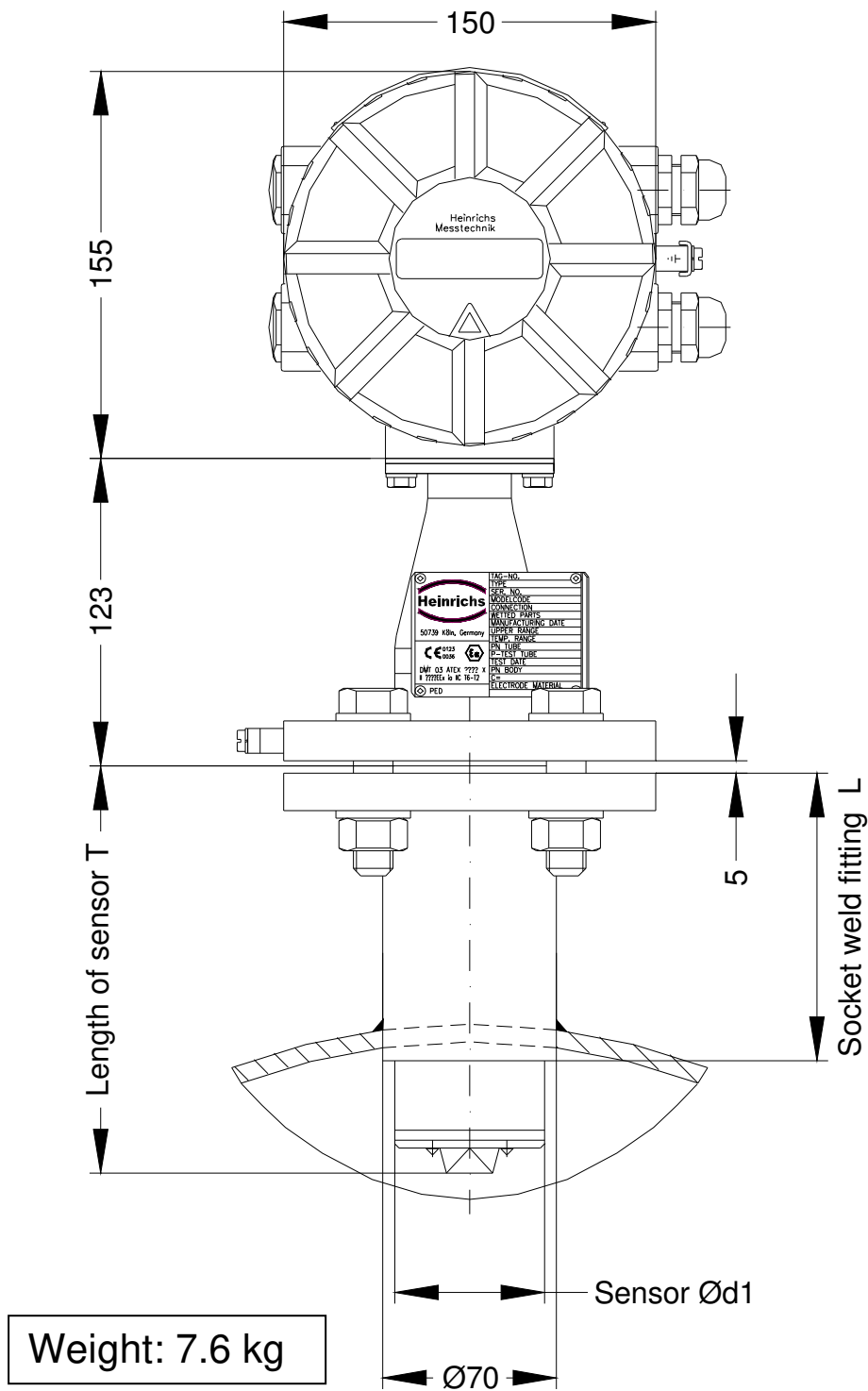

Version	DN	Sensor lining	Length of sensor T	Sensor- \varnothing	Length of weld fitting L
PIT-571	150 - 600	PFA	163	62	145
PIT-573	150 - 600	PVDF	163	62	145
PIT-520	150 - 600	1.4571	163	60,3	145
PIT-520	700 - 1200	1.4571	263	60,3	170
PIT-520	1400 - 2000	1.4571	363	60,3	170

7 Auxiliary power/electrical connection

See type plate or Operating Instructions of the corresponding transmitter

8 CE Mark

The measuring system complies with the legal requirements of the following EU Directives: *94/9/EC (Equipment and Protective Systems for Use in Potentially Explosive Atmospheres)*, *Directive 89/336/EEC (EMC Directive)* and *Directive 97/23/EC (Pressure Equipment Directive)*.

Heinrichs Messtechnik confirms compliance with the directives by attaching the CE mark to the device.

9 Standards and directives, certificates and approvals

Certified to DIN-EN 9001:2008
Production in accordance with AD guidelines and HPO approval (TRB200/TRD201)
TÜV approval for welding requirements in accordance with EN 3842-2

Directive 94/9/EC (Equipment and Protective Systems for Use in Potentially Explosive Atmospheres)

EN 50014:1997+A1-A2	General requirements
EN 50019:2000	Increased safety "e"
EN 50020:1994	Intrinsic safety "i"

The basic security requirements are fulfilled furthermore without the application of the current harmonized standards EN 60079 ff, too.

Directive 89/336/EEC	(EMC Directive)
EN 61000-6-2:1999	Immunity industrial environment
EN 50 081-1	Emitted interference residential environment
EN 55011:1998+A1:1999	Group 1, Class B

Directive 97/23/EC	(Pressure Equipment Directive)
---------------------------	--------------------------------

AD guidelines

NAMUR recommendation NE 21
EN 60529 – Degrees of protection through housing (IP code)
EN 61010 – Safety requirements for electrical measuring, control and laboratory devices

10 Safety information

10.1 Intended use

The PIT-5** flowmeter may be used only for flow measurements of fluids whose conductivity exceeds 20µS/cm. The manufacturer shall not be liable for damages that may result from unintended or inappropriate use.

When dealing with an aggressive medium, clarify the material durability of all wetted parts. When using the device in hazardous areas, the stipulations of the EC Type Examination Certificate and the applicable national installation rules must be followed.

10.2 Installation, start-up and operating personnel

Only trained specialists authorized by the system operator may carry out the installation, electrical installations, start-up,

maintenance and operation. They must read and understand the operating manual and follow its instructions. Basically, the national conditions and provisions must be followed.

11 Packaging, storage and transport

Carefully unpack the device to avoid damaging it.

Storage and installation must be done in a clean and dry room so that contamination – especially of the interior of the fitting – is avoided. The ambient temperature ranges must be observed.

With the help of the delivery note enclosed in the packaging, check whether all technically relevant data coincide with your requirements.

When transporting the device to a remote mounting location, we recommend that you reuse the factory-issued packaging and the transport protection.

12 Maintenance

The device requires no maintenance if used according to its intended purpose. Cleaning might be necessary due to deposits and dirt on the electrodes or the measuring head.

13 Returning devices for repair and service

Note: In accordance with the applicable German waste disposal legislation, the owner/client is responsible for the disposal of special waste and hazardous materials. Consequently, all devices sent to us for repair must be free of any hazardous materials. This also applies to possible hollow spaces and fissures in the devices.

If repair is necessary, confirm the above-mentioned item in writing (**please use the form in the Appendix**).

If hazardous materials remain in or on the device after it has been returned, Heinrichs Messtechnik shall be authorized to remove them at the client's expense without further inquiry.

14 Options

14.1 Dismounting/reinstalling the device under process pressure

In some cases it might be necessary to dismount and reinstall the PIT for cleaning when the pipe is under process pressure. A special mechanism can be used for this purpose.

When using this mechanism, it is important to ensure that the measuring head will not be damaged by closing the valve. For a detailed description of this process, see the Additional Operating Instructions for Dismounting/Reinstalling the Device under Process Pressure (Section 5.1.2).

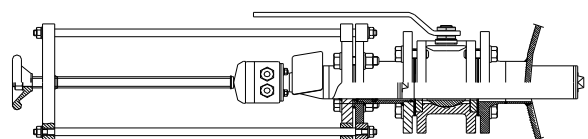

14.2 PIT with IP 68 degree of protection

A special version of PIT is available with the IP 68 degree of protection. This version is equipped with a special terminal box, special cable glands and a special cable. The length of the cable must be specified when placing the order. The terminal box does not need to be opened during the installation. If this should be necessary, the cover must be

remounted carefully. This is the only way to ensure the IP 68 degree of protection.

The maximum depth of immersion is 5 m.

Due to the separate wiring arrangement of intrinsically safe and not intrinsically safe circuits for hazardous area applications, two cables are available for this version.

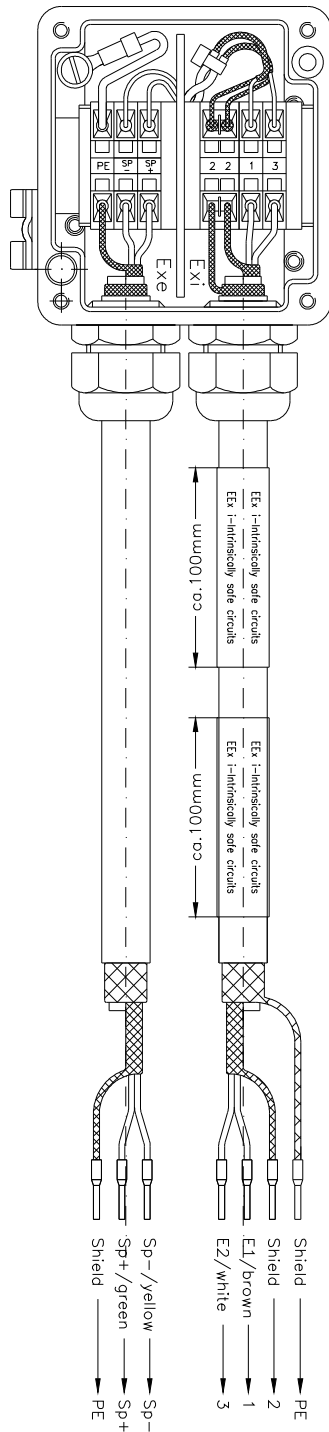

14.2.1 Wiring diagram for IP 68 hazardous area version

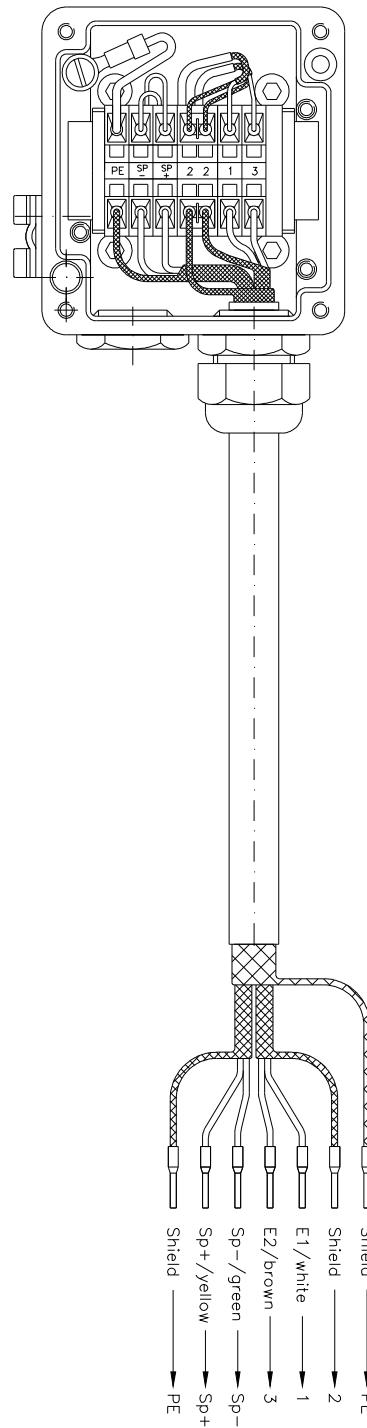

14.2.2 Wiring diagram for IP 68 standard version



15 EC Type Examination Certificate

<div style="display: flex; justify-content: space-between; align-items: center;">   </div> <p style="text-align: center;">Translation</p> <p style="text-align: center;">EC-Type Examination Certificate</p> <p style="text-align: center;">- Directive 94/9/EC - Equipment and protective systems intended for use in potentially explosive atmospheres</p> <p style="text-align: center;">BVS 03 ATEX E 150 X</p> <p>Equipment: Flow Sensor Type PIT-520, Type PIT-571 and Type PIT-580</p> <p>Manufacturer: Heinrichs Messtechnik GmbH</p> <p>Address: D 50739 Köln</p> <p>The design and construction of this equipment and any acceptable variation thereto are specified in the schedule to this type examination certificate.</p> <p>The certification body of Deutsche Montan Technologie GmbH, notified body no. 0158 in accordance with Article 9 of the Directive 94/9/EC of the European Parliament and the Council of 23 March 1994, certifies that this equipment has been found to comply with the Essential Health and Safety Requirements relating to the design and construction of equipment and protective systems intended for use in potentially explosive atmospheres, given in Annex II to the Directive.</p> <p>The examination and test results are recorded in the test and assessment report BVS PP 03.2097 EG.</p> <p>The Essential Health and Safety Requirements are assured by compliance with:</p> <ul style="list-style-type: none"> EN 50014:1997+A1-A2 General requirements EN 50019:2000 Increased safety EN 50020:1994 Intrinsic safety <p>If the sign "X" is placed after the certificate number, it indicates that the equipment is subject to special conditions for safe use specified in the schedule to this certificate.</p> <p>This EC-Type Examination Certificate relates only to the design, examination and tests of the specified equipment in accordance with Directive 94/9/EC. Further requirements of the Directive apply to the manufacturing process and supply of this equipment. These are not covered by this certificate</p> <p>The marking of the equipment shall include the following:</p> <p style="text-align: center;">Ex II 2G EEx e [ia] IIC T3-T6</p> <p style="text-align: right;">Deutsche Montan Technologie GmbH Essen, dated 16. May 2003</p> <p style="text-align: right;">Signed: <u>Jockers</u> DMT-Certification body</p> <p style="text-align: right;">Signed: <u>Eickhoff</u> Head of special services unit</p>	<div style="display: flex; justify-content: space-between; align-items: center;">  </div> <p style="text-align: center;">Appendix to</p> <p style="text-align: center;">EC-Type Examination Certificate</p> <p style="text-align: center;">BVS 03 ATEX E 150 X</p> <p>(13) (14) (15) <u>15.1 Subject and type</u> Flow Sensor Type PIT-520, Type PIT-571 und Type PIT-580</p> <p><u>15.2 Description</u> The flow sensor, using the principle of magnetic induction, serves for the flow measurement of conductive fluids. The mounting flange of the sensor is laterally attached to the pipe containing the fluid. For power supply and for signal evaluation, the sensor is used in conjunction with a signal transducer type UMF (DMT 99 ATEX E 107 X) which is directly mounted to the sensor (compact version). Alternatively, the sensor is provided with a connection box; the associated signal transducer, separately certified, is connected to the sensor by means of a cable (separated version).</p> <p><u>15.3 Parameters</u></p> <p>15.3.1 Electrical parameters</p> <table style="width: 100%; border-collapse: collapse;"> <tr> <td style="width: 60%;">Rated voltage</td> <td style="width: 20%;">up to</td> <td style="width: 20%;">60 V</td> </tr> <tr> <td>Rated current</td> <td></td> <td>200 mA</td> </tr> <tr> <td>Maximum current</td> <td></td> <td>250 mA</td> </tr> <tr> <td>Pulse frequency</td> <td></td> <td>25 Hz</td> </tr> </table> <p>15.3.1.1 Field coil circuit</p> <table style="width: 100%; border-collapse: collapse;"> <tr> <td style="width: 60%;">Voltage U_i</td> <td style="width: 20%;">24 V</td> </tr> <tr> <td>Current I_i</td> <td>160 mA</td> </tr> <tr> <td>Capacitance C_i</td> <td>negligible</td> </tr> <tr> <td>Inductance L_i</td> <td>negligible</td> </tr> </table> <p>15.3.1.2 Electrode circuit (separated version), intrinsically safe category ia</p> <table style="width: 100%; border-collapse: collapse;"> <tr> <td style="width: 60%;">Current I_i</td> <td style="width: 20%;">negligible</td> </tr> <tr> <td>Capacitance C_i</td> <td>negligible</td> </tr> <tr> <td>Inductance L_i</td> <td>negligible</td> </tr> </table> <p>15.3.1.3 Electrode circuit (compact version), intrinsically safe</p> <p>As defined in the relevant EC-Type Examination Certificate for the signal transducer</p> <p>15.3.1.4 Transducer circuits</p> <p>As defined in the relevant EC-Type Examination Certificate</p> <p style="text-align: right;">Page 1 of 4 to BVS 03 ATEX E 150 X This certificate may only be reproduced in its entirety and without change. Am Technologiepark 1, 45397 Essen, Telefon (0203) 7172-1416, Telefax (0203) 7172-1716</p>	Rated voltage	up to	60 V	Rated current		200 mA	Maximum current		250 mA	Pulse frequency		25 Hz	Voltage U _i	24 V	Current I _i	160 mA	Capacitance C _i	negligible	Inductance L _i	negligible	Current I _i	negligible	Capacitance C _i	negligible	Inductance L _i	negligible
Rated voltage	up to	60 V																									
Rated current		200 mA																									
Maximum current		250 mA																									
Pulse frequency		25 Hz																									
Voltage U _i	24 V																										
Current I _i	160 mA																										
Capacitance C _i	negligible																										
Inductance L _i	negligible																										
Current I _i	negligible																										
Capacitance C _i	negligible																										
Inductance L _i	negligible																										



15.3.2 Thermal data

Type designation and version	Maximum fluid temperature (°C)	Ambient temperature (°C)	Temperature class
PIT-520/PIT-580 separated version	60	-40 up to +50	T6
PIT-520/PIT-580 separated version	80	-40 up to +60	T5
PIT-520/PIT-580 compact version	60	-20 up to +50	T6
PIT-520/PIT-580 compact version	80	-20 up to +55	T5
PIT-571 separated version	60	-40 up to +45	T6
PIT-571 separated version	60	-40 up to +60	T5
PIT-571 separated version	100	-40 up to +60	T4
PIT-571 separated version	130	-40 up to +60	T3
PIT-571 compact version	60	-20 up to +45	T6
PIT-571 compact version	60	-20 up to +55	T5
PIT-571 compact version	100	-20 up to +50	T4
PIT-571 compact version	130	-20 up to +50	T3

Thermal data of the separate transducers in accordance with the EC-Type Examination Certificate of the transducers.

15.3.3 Permissible fluid pressure

Sensor type PIT-520 and type PIT-580	16 bar
Sensor type PIT-571	40 bar

(16) Test and assessment report

BVS PP 03.2097 EG as of 16.05.2003

(17) Special conditions for safe use

- 17.1 It shall be ensured that there are no detrimental effects to the materials of the sensor caused by the fluids.
- 17.2 The flow sensor is designed for use in an ambient temperature range of -40°C up to +60°C.
- It shall be ensured that the data as defined under 15.3.2 for the ambient temperature, the fluid temperature and the temperature class are met.
- 17.3 For sensors of the separate version which are used at an ambient temperature of less than -20 °C suitable cables and cable entry devices certified for this condition shall be used.
- 17.4 The special conditions for safe operation as defined in the relevant EC-Type Examination Certificate for the signal transducers shall be observed.
- 17.5 If the mass flow transmitter is connected by conduit entries they must be certified for this purpose and the associated stopping boxes must be mounted immediately to the enclosure.
- 17.6 The control device type BE is designed for use in an ambient temperature range of -20°C up to +70°C.

16 Decontamination certificate for device cleaning

Company:

City:

Department:

Name:

Tel. No.:

This flowmeter

type PIT-5

was operated using the measured medium.....

Since this measured medium is dangerous in water/poisonous/corrosive/flammable,

we have

- checked that all hollow spaces of the device are free of these materials*
- neutralized and flushed all hollow spaces of the device*

*cross out what is not applicable.

We hereby confirm that in resending the device no danger to persons or the environment is posed by the residual measured substance.

Date:

Signature:

Stamp